

District 5  
Capital Improvement Project  
Priority Rating Sheet, Round 35

CITY OF NAPOLGON - WWTP CREDIT ENHANCEMENT

COUNTY: PROJECT: #14,942,589 PROJECT NUMBER:  
EST. COST:

No.	*A* WEIGHT FACTOR	CRITERIA TO BE CONSIDERED	*B* PRIORITY FACTORS						*A* x *B*	PRIORITY FACTORS						No.	
			0	2	4	6	8	10		0	2	4	6	8	10		
1	1	(REPAIR OR REPLACE) vs. (NEW OR EXPANSION)				X			8	0%+	20%+	40%+	60%+	80%+	100%+	1	
2A	1	EXISTING PHYSICAL CONDITION Please refer to Criteria #2 of the Round 35 Scoring Methodology. Must submit substantiating documentation. (100% New or Expansion = 0 Points)				X			8	Excellent	Good	Fair	Fading	Poor	Failing	2A	
2B	1	AGE					X		5	Road Type	0-4 Yrs	5-8 Yrs	9-12 Yrs	13-16 Yrs	17-20 Yrs	20+ Yrs	2B
										Wastewater	0-6 Yrs	7-12 Yrs	13-18 Yrs	19-24 Yrs	25-30 Yrs	30+ Yrs	
										Sanitary Sewer, Water Supply, Storm Water, Solid Waste	0-10 Yrs	11-20 Yrs	21-30 Yrs	31-40 Yrs	41-50 Yrs	50+ Yrs	
3	2	PUBLIC HEALTH AND/OR SAFETY CONCERNS Submittals without supporting documentation will receive 0 points for this question.					X		20	No Impact	Minimal	Moderate	Major	Critical	Extremely Critical	3	
4	2	LOCAL MATCHING FUNDS Percentage of Local Share (Local funds are funds derived from the applicant budget or a loan to be paid back through the applicant budget, assessments, rates or tax revenues) *						X	20	0%	10%	20%	30%	40%	50%	4	
5	1	OTHER FUNDING (Excluding Issue II Funds) (Grants and other revenues not contributed or collected through taxes by the applicant, including Gifts, Contributions, etc. -- must submit copy of award or status letter.)	X						6	0%	10%	20%	30%	40%	50%	5	
6	2	OPWC GRANT AND LOAN FUNDS REQUESTED. Please refer to Criteria #5 of the Round 35 Methodology for clarification.						X	18	Grant or Loan Only	-9	-8	0	8	9	10	6
										Grant/Loan Combination	\$750,000 or more	\$600,001 to \$750,000	\$487,501 to \$600,000	\$412,501 to \$487,500	\$262,501 to \$412,500	\$262,500 or less	6
When scoring a project that is only grant or only loan, please use the chart labeled "Grant or Loan Only". When scoring a grant/loan combination, score the project for the grant in the first chart, then use the second chart labeled "Grant/Loan Combination" to score the total (grant and loan combined). Use the lower of the two as the score.																	
7	1	JOB CREATION/RETENTION Indicate full time equivalent jobs. Include supporting documentation in the form of a commitment letter from business or third party entity.	X						0	0-6 Jobs	7-14 Jobs	15-24 Jobs	25+ Jobs			7	
8	1	BENEFIT TO EXISTING USERS (households or traffic counts) Lightweight surveying with direct connections. Traffic Counts within two years with certified documentation, etc.					X		10	0-99 Users	100-349 Users	350-499 Users	500-749 Users	750-1000 Users	1000+ Users	8	
9	1	ECONOMIC DISTRESS Local MHI as a percentage of the District Median MHI	X						1	100%+	80%-100%	Less Than 80%			9		
10	1	READINESS TO PROCEED	X						1	Plans Not Begun Yet	Preliminary Engineering Complete	Final Design Complete			10		
11		SUBTOTAL RANKING POINTS (MAX. = 115)							91	Other info: Does this project have a significant impact on productive farmland? YES NO Attach impact statement if yes. Is the Applicant ready to proceed to bids after State Approval within 6 months? YES NO							
12		COUNTY SUBCOMMITTEE PRIORITY POINTS (25-20.15)															
13A		DISCRETIONARY POINTS (BY DISTRICT ONLY) (MAX.=1)								District Discretionary Point may be awarded to projects that demonstrate significant Area-wide, County, or Community Impact. Include documentation to support the claim of significance.							
13B		DISCRETIONARY POINTS (BY DISTRICT ONLY) (MAX.=1)								District Discretionary Point may be awarded to projects that demonstrate that the entity has maximized financial resources including assessments and utility rate structure.							
14		GRAND TOTAL RANKING POINTS															

\* Applicants must certify local and other share contributions. Specify, all funding sources to be utilized as local share at the time of application submittal.



State of Ohio  
**Public Works Commission**  
*Application for Financial Assistance*

**IMPORTANT:** Please consult "Instructions for Financial Assistance for Capital Infrastructure Projects" for guidance in completion of this form.

**Applicant** Applicant: City of Napoleon Subdivision Code: 069-53550  
 District Number: 5 County: Henry Date: 09/09/2020  
 Contact: Chad E. Lulfs, P.E., P.S. Phone: (419) 592-4010  
(The Individual who will be available during business hours and who can best answer or coordinate the response to questions)  
 Email: clulfs@napoleonohio.com FAX: (419) 599-8393

Project Name: 2021 WWTP Improvements Zip Code: 43545

Project	Subdivision Type <small>(Select one)</small>	Project Type <small>(Select single largest component by \$)</small>	Funding Request Summary <small>(Automatically populates from page 2)</small>
<input type="checkbox"/>	1. County	<input type="checkbox"/>	Total Project Cost: <u>14,942,589 .00</u>
<input checked="" type="checkbox"/>	2. City	<input type="checkbox"/>	1. Grant: <u>0 .00</u>
<input type="checkbox"/>	3. Township	<input type="checkbox"/>	2. Loan: <u>0 .00</u>
<input type="checkbox"/>	4. Village	<input checked="" type="checkbox"/>	3. Loan Assistance/ Credit Enhancement: <u>236,006 .00</u>
<input type="checkbox"/>	5. Water (8119 Water District)	<input type="checkbox"/>	Funding Requested: <u>236,006 .00</u>
		<input type="checkbox"/>	
		<input type="checkbox"/>	

**District Recommendation** (To be completed by the District Committee)

Funding Type Requested <small>(Select one)</small>	SCIP Loan - Rate: _____ % Term: _____ Yrs	Amount: _____ .00
<input type="checkbox"/> State Capital Improvement Program	RLP Loan - Rate: _____ % Term: _____ Yrs	Amount: _____ .00
<input type="checkbox"/> Local Transportation Improvement Program	Grant:	Amount: _____ .00
<input type="checkbox"/> Revolving Loan Program	LTIP:	Amount: _____ .00
<input type="checkbox"/> Small Government Program	Loan Assistance / Credit Enhancement:	Amount: _____ .00
District SG Priority: _____		

**For OPWC Use Only**

STATUS	Grant Amount: _____ .00	Loan Type: <input type="checkbox"/> SCIP <input type="checkbox"/> RLP
Project Number: _____	Loan Amount: _____ .00	Date Construction End: _____
	Total Funding: _____ .00	Date Maturity: _____
Release Date: _____	Local Participation: _____ %	Rate: _____ %
OPWC Approval: _____	OPWC Participation: _____ %	Term: _____ Yrs

**1.0 Project Financial Information (All Costs Rounded to Nearest Dollar)**

**1.1 Project Estimated Costs**

**Engineering Services**

Preliminary Design:	<u>469,100</u> .00		
Final Design:	<u>670,983</u> .00		
Construction Administration:	<u>0</u> .00		
<b>Total Engineering Services:</b>	<b>a.)</b>	<b><u>1,140,083</u> .00</b>	<b><u>9</u> %</b>
Right of Way:	<b>b.)</b>	<u>0</u> .00	
Construction:	<b>c.)</b>	<u>12,315,000</u> .00	
Materials Purchased Directly:	<b>d.)</b>	<u>0</u> .00	
Permits, Advertising, Legal:	<b>e.)</b>	<u>256,006</u> .00	
Construction Contingencies:	<b>f.)</b>	<u>1,231,500</u> .00	<u>10</u> %
<b>Total Estimated Costs:</b>	<b>g.)</b>	<b><u>14,942,589</u> .00</b>	

**1.2 Project Financial Resources**

**Local Resources**

Local In-Kind or Force Account:	<b>a.)</b>	<u>0</u> .00	
Local Revenues:	<b>b.)</b>	<u>0</u> .00	
Other Public Revenues:	<b>c.)</b>	<u>0</u> .00	
ODOT / FHWA PID: _____	<b>d.)</b>	<u>0</u> .00	
USDA Rural Development:	<b>e.)</b>	<u>0</u> .00	
OEPA / OWDA:	<b>f.)</b>	<u>14,706,583</u> .00	
CDBG:	<b>g.)</b>	<u>0</u> .00	
<input type="checkbox"/> County Entitlement or Community Dev. "Formula"			
<input type="checkbox"/> Department of Development			
Other: _____	<b>h.)</b>	<u>0</u> .00	
<b>Subtotal Local Resources:</b>	<b>i.)</b>	<b><u>14,706,583</u> .00</b>	<b><u>98</u> %</b>

**OPWC Funds (Check all requested and enter Amount)**

Grant: <u>0</u> % of OPWC Funds	<b>j.)</b>	<u>0</u> .00	
Loan: <u>100</u> % of OPWC Funds	<b>k.)</b>	<u>0</u> .00	
Loan Assistance / Credit Enhancement:	<b>l.)</b>	<u>236,006</u> .00	
<b>Subtotal OPWC Funds:</b>	<b>m.)</b>	<b><u>236,006</u> .00</b>	<b><u>2</u> %</b>
<b>Total Financial Resources:</b>	<b>n.)</b>	<b><u>14,942,589</u> .00</b>	<b><u>100</u> %</b>

### 1.3 Availability of Local Funds

Attach a statement signed by the Chief Financial Officer listed in section 5.2 certifying all local resources required for the project will be available on or before the earliest date listed in the Project Schedule section. The OPWC Agreement will not be released until the local resources are certified. Failure to meet local share may result in termination of the project. Applicant needs to provide written confirmation for funds coming from other funding sources.

### 2.0 Repair / Replacement or New / Expansion

2.1 Total Portion of Project Repair / Replacement:	<u>13,442,589</u> .00	<u>90</u> %	A Farmland Preservation letter is required for any impact to farmland
2.2 Total Portion of Project New / Expansion:	<u>1,500,000</u> .00	<u>10</u> %	
2.3 Total Project:	<u>14,942,589</u> .00	<u>100</u> %	

### 3.0 Project Schedule

3.1 Engineering / Design / Right of Way	Begin Date: <u>08/06/2019</u>	End Date: <u>10/30/2020</u>
3.2 Bid Advertisement and Award	Begin Date: <u>12/07/2020</u>	End Date: <u>01/29/2021</u>
3.3 Construction	Begin Date: <u>03/01/2021</u>	End Date: <u>12/31/2022</u>

Construction cannot begin prior to release of executed Project Agreement and issuance of Notice to Proceed.

Failure to meet project schedule may result in termination of agreement for approved projects. Modification of dates must be requested in writing by project official of record and approved by the Commission once the Project Agreement has been executed.

### 4.0 Project Information

If the project is multi-jurisdictional, information must be consolidated in this section.

#### 4.1 Useful Life / Cost Estimate / Age of Infrastructure

Project Useful Life: 30 Years      Age: 1959 (Year built or year of last major improvement)

*Attach Registered Professional Engineer's statement, with seal or stamp and signature confirming the project's useful life indicated above and detailed cost estimate.*

#### 4.2 User Information

Road or Bridge:      Current ADT \_\_\_\_\_ Year \_\_\_\_\_      Projected ADT \_\_\_\_\_ Year \_\_\_\_\_

Water / Wastewater: Based on monthly usage of 4,500 gallons per household; attach current ordinances.

Residential Water Rate      Current \$ 55.35      Proposed \$ 55.35

Number of households served: 3,186

Residential Wastewater Rate      Current \$ 74.13      Proposed \$ 74.13

Number of households served: 3,177

Stormwater: Number of households served: 3,903

## 4.3 Project Description

- A: SPECIFIC LOCATION** (Supply a written location description that includes the project termini; a map does not replace this requirement.) 500 character limit.

The project is the City of Napoleon's Wastewater Treatment Plant (WWTP), which is located at 635 E. Washington Street.

- B: PROJECT COMPONENTS** (Describe the specific work to be completed; the engineer's estimate does not replace this requirement) 1,000 character limit.

The project consists of: replacement of the existing headworks facility; replacement of degritting and screens; cleaning of existing digesters and transitioning to aerobic digestion; upgrading/replacement of the dewatering equipment; repair/stabilization of the existing protective dike; replacement of pumps, piping, and associated mechanical/electrical; replacement of gates, valves, and miscellaneous flow control systems and structures.

- C: PHYSICAL DIMENSIONS** (Describe the physical dimensions of the existing facility and the proposed facility. Include length, width, quantity and sizes, mgd capacity, etc in detail.) 500 character limit.

The existing facility has a capacity of 2.5 MGD. The upgraded facility will have a capacity of 7.5 MGD. The existing headworks facility will be replaced; screens/degritting will be replaced. Digesters will be converted from anaerobic to aerobic digestion. Belt presses will be replaced with screw presses to handle additional loading. Pumps, piping, electrical, mechanical, and controls will be replaced with upgraded components and sized for the increased capacity.

## 5.0 Project Officials

Changes in Project Officials must be submitted in writing from an officer of record.

### 5.1 Chief Executive Officer (Person authorized in legislation to sign project agreements)

Name: Joel L. Mazur  
Title: City Manager  
Address: 255 W. Riverview Avenue  
P.O. Box 151  
City: Napoleon State: OH Zip: 43545  
Phone: (419) 592-4010  
FAX: (419) 599-8393  
E-Mail: jmazur@napoleonohio.com

### 5.2 Chief Financial Officer (Can not also serve as CEO)

Name: Kelly O'Boyle  
Title: Finance Director  
Address: 255 W. Riverview Avenue  
P.O. Box 151  
City: Napoleon State: OH Zip: 43545  
Phone: (419) 592-4010  
FAX: (419) 599-8393  
E-Mail: koboyle@napoleonohio.com

### 5.3 Project Manager

Name: Chad E. Lulfs, P.E., P.S.  
Title: Director of Public Works  
Address: 255 W. Riverview Avenue  
P.O. Box 151  
City: Napoleon State: OH Zip: 43545  
Phone: (419) 592-4010  
FAX: (419) 599-8393  
E-Mail: clulfs@napoleonohio.com

## 6.0 Attachments / Completeness review

Confirm in the boxes below that each item listed is attached (Check each box)

- A certified copy of the legislation by the governing body of the applicant authorizing a designated official to sign and submit this application and execute contracts. This individual should sign under 7.0, Applicant Certification, below.
- A certification signed by the applicant's chief financial officer stating the amount of all local share funds required for the project will be available on or before the dates listed in the Project Schedule section. If the application involves a request for loan (RLP or SCIP), a certification signed by the CFO which identifies a specific revenue source for repaying the loan also must be attached. Both certifications can be accomplished in the same letter.
- A registered professional engineer's detailed cost estimate and useful life statement, as required in 164-1-13, 164-1-14, and 164-1-16 of the Ohio Administrative Code. Estimates shall contain an engineer's seal or stamp and signature.
- A cooperative agreement (if the project involves more than one subdivision or district) which identifies the fiscal and administrative responsibilities of each participant.
- Farmland Preservation Review - The Governor's Executive Order 98-IV, "Ohio Farmland Protection Policy" requires the Commission to establish guidelines on how it will take protection of productive agricultural and grazing land into account in its funding decision making process. Please include a Farm Land Preservation statement for projects that have an impact on farmland.
- Capital Improvements Report. CIR Required by O.R.C. Chapter 164.06 on standard form.
- Supporting Documentation: Materials such as additional project description, photographs, economic impact (temporary and/or full time jobs likely to be created as a result of the project), accident reports, impact on school zones, and other information to assist your district committee in ranking your project. Be sure to include supplements which may be required by your local District Public Works Integrating Committee.

## 7.0 Applicant Certification

The undersigned certifies: (1) he/she is legally authorized to request and accept financial assistance from the Ohio Public Works Commission as identified in the attached legislation; (2) to the best of his/her knowledge and belief, all representations that are part of this application are true and correct; (3) all official documents and commitments of the applicant that are part of this application have been duly authorized by the governing body of the applicant; and, (4) should the requested financial assistance be provided, that in the execution of this project, the applicant will comply with all assurances required by Ohio Law, including those involving Buy Ohio and prevailing wages.

**Applicant certifies that physical construction on the project as defined in the application has NOT begun, and will not begin until a Project Agreement for this project has been executed with the Ohio Public Works Commission. Action to the contrary will result in termination of the agreement and withdrawal of Ohio Public Works Commission funding from the project.**

Joel L. Mazur, City Manager

Certifying Representative (Printed form, Type or Print Name and Title)

 9/9/20  
Original Signature / Date Signed

RESOLUTION NO. 037-20

**A RESOLUTION AUTHORIZING THE CITY MANAGER TO EXECUTE ALL DOCUMENTS NECESSARY TO APPLY FOR AND ACCEPT OHIO PUBLIC WORKS COMMISSION STATE CAPITAL IMPROVEMENT PROGRAM (SCIP) AND LOCAL TRANSPORTATION IMPROVEMENT PROGRAM (LTIP) FUNDS FOR PROJECTS DEEMED NECESSARY BY THE CITY ENGINEER IN THE YEAR 2021; AND DECLARING AN EMERGENCY**

**BE IT RESOLVED BY THE COUNCIL OF THE CITY OF NAPOLEON, OHIO:**

Section 1. That, the City Manager is directed to execute all documents necessary to apply for and accept Ohio Public Works Commission State Capital Improvement Program (SCIP) and Local Transportation Improvement Program (LTIP) funds for the year for projects deemed necessary by the City Engineer in the Year 2021, including but not limited to execution of Grant Agreement(s).

Section 2. That, it is found and determined that all formal actions of this City Council concerning and relating to the adoption of this Resolution were adopted in open meetings of this City Council, and that all deliberations of this City Council and any of its committees that resulted in such formal actions were in compliance with all legal requirements, including Section 121.22 of the Ohio Revised Code and the Codified Ordinances of Napoleon Ohio.

Section 3. That, if any other prior Ordinance or Resolution is found to be in conflict with this Resolution, then the provisions of this Resolution shall prevail. Further, if any portion of this Resolution is found to be invalid for any reason, such decision shall not affect the validity of the remaining portions of this Resolution or any part thereof.

Section 4. That, this Resolution is declared to be an emergency measure necessary for the immediate preservation of the public peace, health or safety of the City and its inhabitants, and for the further reason that this legislation must be in effect at the earliest possible time to assure the prompt and efficient application for project funds related to public peace, health or safety of the City; therefore, provided it receives the required number of votes for passage as emergency legislation, it shall be in full force and effect immediately upon its passage; otherwise, it shall be in full force and effect at the earliest time permitted by law. Further, the Emergency Clause is necessary to be in effect at the earliest possible time to allow for proper and timely application of grant funds, and for further reasons as stated in the Preamble hereof.

Passed: September 8, 2020

  
Joseph D. Bialorucki, Council President

Approved: September 8, 2020

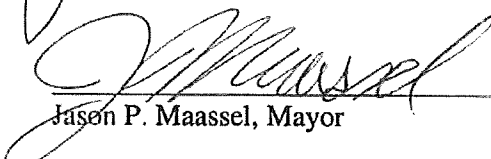
  
Jason P. Maassel, Mayor



VOTE ON PASSAGE 7 Yea 0 Nay 0 Abstain

Attest:

Roxanne Dietrich  
Roxanne Dietrich, Clerk of Council

*I, Roxanne Dietrich, Clerk of Council for the City of Napoleon, do hereby certify that the foregoing Resolution No. 037-20 was duly published in the Northwest Signal, a newspaper of general circulation in said City, on the \_\_\_\_\_ day of \_\_\_\_\_, 2020; & I further certify the compliance with rules established in Chapter 103 of the Codified Ordinances Of Napoleon Ohio and the laws of the State of Ohio pertaining to Public Meetings.*

\_\_\_\_\_  
Roxanne Dietrich, Clerk of Council

**Certification**

I, Roxanne Dietrich, Clerk of Council for the City of Napoleon, Ohio, do hereby certify that this document is a true and correct copy of Resolution No. 037-20 passed September 8, 2020.

Roxanne Dietrich  
Roxanne Dietrich  
Clerk of Council

September 8, 2020  
Date

## **STATUS OF FUNDS REPORT**

The requested funds for the proposed improvements will be paid through revenues produced from sewer rates. Enclosed is Ordinance No. 058-18 establishing sewer rates for customers inside and outside of the corporation limits of the City.

The 2021 Wastewater Treatment Plant Improvements Project will be included in the 2021 City of Napoleon Budget, subject to appropriation by City Council.

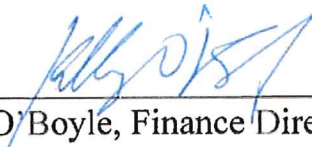
  
\_\_\_\_\_  
Kelly O'Boyle, Finance Director

**CITY OF NAPOLEON, OHIO  
FRONT STREET INTERCEPTOR &  
PALMER DITCH FORCEMAIN RELOCATION**

**Engineer's Estimate of Construction**

<b>ITEM</b>		<b>ESTIMATED</b>			
<b><u>NO.</u></b>	<b><u>DESCRIPTION</u></b>	<b><u>QUANTITY</u></b>	<b><u>UNIT</u></b>	<b><u>UNIT PRICE</u></b>	<b><u>TOTAL</u></b>
<b><i>SANITARY SEWER</i></b>					
1	Clearing & Grubbing	1	LS	\$10,000.00	\$10,000.00
2	4-1/2" Asphalt Concrete Base (ODOT 301 PG64-22)	10	CY	\$250.00	\$2,500.00
3	1-1/2" Asphalt Concrete Surface Course (ODOT 823 Type 1 Medium, PG64-22)	7	CY	\$350.00	\$2,450.00
4	12" PVC ASTM D3034 SDR-35 Sanitary (Type B)	30	LF	\$100.00	\$3,000.00
4	30" PVC ASTM F679 Sanitary (Type B)	100	LF	\$250.00	\$25,000.00
5	30" PVC ASTM F679 Sanitary (Type C)	630	LF	\$225.00	\$141,750.00
6	10" AWWA C909 & DR18 Force Main, Type C	530	LF	\$80.00	\$42,400.00
7	10" 45 Degree MJ Bend	6	EA	\$750.00	\$4,500.00
8	Connection to Existing Screw Pump Lift Station	1	EA	\$2,500.00	\$2,500.00
9	Sanitary Manhole Abandoned	1	EA	\$1,500.00	\$1,500.00
10	48" Diameter Sanitary Manhole With Standard Cone	1	EA	\$5,500.00	\$5,500.00
11	60" Diameter Sanitary Manhole With Standard Cone	4	EA	\$7,500.00	\$30,000.00
12	60" Diameter Sanitary Manhole With Flat Slab Top & Gooseneck Vent, Complete	1	EA	\$10,000.00	\$10,000.00
13	72" Diameter Sanitary Manhole With Flat Slab Top	1	EA	\$10,000.00	\$10,000.00
14	Sanitary Manhole Casting with Gasketed Lid Marked "SANITARY SEWER"	7	EA	\$700.00	\$4,900.00
15	Sanitary Sewer Televising	730	LF	\$2.00	\$1,460.00
16	3" Topsoil Hauled and Placed	350	CY	\$50.00	\$17,500.00

**CITY OF NAPOLEON, OHIO  
FRONT STREET INTERCEPTOR &  
PALMER DITCH FORCEMAIN RELOCATION**

**Engineer's Estimate of Construction**

<b>ITEM</b>	<b>ESTIMATED</b>				
<b><u>NO.</u> <u>DESCRIPTION</u></b>	<b><u>QUANTITY</u></b>	<b><u>UNIT</u></b>	<b><u>UNIT PRICE</u></b>	<b><u>TOTAL</u></b>	
17 Fertilizer, Seeding, and Mulching	4000	SY	\$2.00	\$8,000.00	
18 Construction Layout Stakes	1	LS	\$7,500.00	\$7,500.00	
19 Maintaining Traffic	1	LS	\$2,000.00	\$2,000.00	
20 Mobilization	1	LS	\$12,000.00	\$12,000.00	
21 Stormwater Pollution Prevention Plan	1	LS	\$2,352.09	\$2,352.09	
<b>ESTIMATED COST OF SANITARY SEWER CONSTRUCTION:</b>				<b>\$346,812.09</b>	
<b>10% CONSTRUCTION CONTINGENCY:</b>				<b>\$34,681.21</b>	
<b>O.E.P.A. FEES</b>				<b>\$1,363.84</b>	
<b>PROPERTY ACQUISITION COSTS:</b>				<b>\$10,000.00</b>	
<b>TOTAL ESTIMATED PROJECT COST:</b>				<b>\$392,857.14</b>	

These costs are based on the utilization of Prevailing Wage rates for labor as established by the Department of Industrial Relations.

The estimated useful life of these improvements is fifty (50) years.

  
 Chad E. Lulfs, P.E., P.S.  
 Director of Public Works  
 City of Napoleon, Ohio

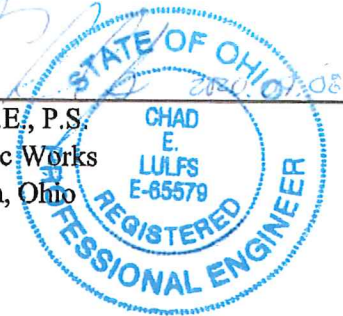

Napoleon Engineering Department  
Napoleon, Ohio  
2020.09.08

**CITY OF NAPOLEON, OHIO  
2021 WWTP IMPROVEMENTS**

**Engineer's Estimate of Construction**

<b>ITEM NO. DESCRIPTION</b>	<b><u>TOTAL</u></b>
<b><i>WASTEWATER TREATMENT</i></b>	
1 General	\$1,906,000.00
2 Sitework	\$1,625,000.00
3 Concrete	\$1,028,000.00
4 Masonry	\$275,000.00
5 Metals	\$245,000.00
6 Wood & Plastics	\$92,000.00
7 Thermal & Moisture Protection	\$28,000.00
8 Doors & Windows	\$103,000.00
9 Finishes	\$117,000.00
10 Specialties	\$5,000.00
11 Equipment & Systems	\$3,276,000.00
12 Furnishings	\$2,000.00
13 Special Construction	\$51,000.00
14 Conveying Systems	\$45,000.00
15 Mechanical	\$2,005,000.00
16 Electrical	\$1,512,000.00
<b>ESTIMATED COST OF SANITARY SEWER CONSTRUCTION:</b>	<b>\$12,315,000.00</b>
<b>10% CONSTRUCTION CONTINGENCY:</b>	<b>\$1,231,500.00</b>
<b>ESTIMATED INTEREST DURING CONSTRUCTION:</b>	<b>\$236,006.00</b>
<b>ENGINEERING DESIGN (ACTUAL):</b>	<b>\$1,140,083.00</b>
<b>ESTIMATED O.E.P.A. FEES:</b>	<b>\$20,000.00</b>
<b>TOTAL PROJECT ESTIMATED COST:</b>	<b>\$14,942,589.00</b>

These costs are based on the utilization of Prevailing Wage rates for labor as established by the Department of Industrial Relations.

The estimated useful life of these improvements is thirty (30) years.

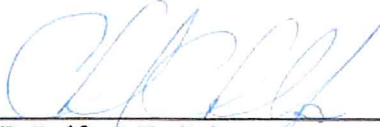
  
Chad E. Lulfs, P.E., P.S.  
Director of Public Works  
City of Napoleon, Ohio



City of Napoleon Engineering Department  
Napoleon, Ohio  
2020.09.09

BEFORE THE  
OHIO ENVIRONMENTAL PROTECTION AGENCY

OHIO E.P.A.  
JUL 25 2000

ENTERED DIRECTOR'S JOURNAL

In the matter of:  
City of Napoleon : Director's Final Findings  
Henry County : and Orders  
P.O. Box 151  
Napoleon, Ohio 43545

**Jurisdiction**

Pursuant to Ohio Revised Code (ORC) Chapter 6111, the Director of the Environmental Protection Agency hereby makes the following Findings and issues the following Orders:

**Parties Bound**

These orders shall apply to and be binding upon the City of Napoleon, hereinafter "Respondent", its assigns and successors in interest. No change in ownership or operation of the Napoleon Publicly Owned Treatment Works, hereinafter "Facility", will in any way alter Respondent's responsibilities under these Orders. Respondent's obligations under these orders may be altered only by the written approval of the Director of the Ohio EPA.

**Findings of Fact**

1. Respondent owns and operates the Napoleon Wastewater Treatment Plant (WWTP) located at 4735 E. Washington St. , Napoleon, Ohio, and the associated collection system. Collectively, the WWTP and its collection system are hereinafter referred to as the Napoleon Publicly Owned Treatment Works (Napoleon POTW), or the "Facility".
2. The Napoleon POTW discharges "sewage", "industrial waste", and/or "other wastes", as those terms are defined in ORC Section 6111.01, to the Maumee River, and Oberhaus Creek and their tributaries.
3. The Maumee River, Oberhaus Creek, and their tributaries constitute "waters of the state" as defined by ORC Section 6111.01.
4. The Respondent holds NPDES permit number 2PD00000\*LD (OH0020893), issued May 24, 1994, which authorizes the city to discharge from the Napoleon POTW to waters of the state. The permit was effective from July 1, 1994 through June 30, 1999.
5. The collection system consists of both combined sewer areas, where it is

I certify this to be a true and accurate copy of the official document as filed in the records of the Ohio Environmental Protection Agency.

By: Ronald J. [Signature] Date 7-25-00

designed to convey both sewage and storm water during wet weather, and separate sanitary sewers, which are not designed to convey storm water except in insignificant amounts. In addition to the discharges from the treatment plant, Respondent's NPDES permit includes four collection system overflows and a WWTP Bypass, which during wet weather discharge to the Maumee River and Oberhaus Creek.

6. NPDES permit No. 2PD00000\*LD included a compliance schedule for the submittal of a CSO Operational Plan by January 1, 1996. The plan was received on January 2, 1996. This plan identified ten unpermitted collection system overflows: three on a combined sewer system and seven on a separated sanitary sewer. The plan also indicated that two of the permitted overflows were SSOs.
7. Since the time of the CSO Operational Plan's submittal, two of the unpermitted CSOs and one of the unpermitted SSOs have been eliminated.
8. Respondent has implemented, and continues to implement, the nine minimum control measures to reduce and eliminate CSO's in its system.
9. The remaining unpermitted SSOs are as follows:

<u>Outfall #</u>	<u>Location</u>	<u>Receiving Sewer</u>	<u>Stream</u>
5	W. Clinton & Sheffield	River	Maumee River
7	Scott & Oberhaus Creek	Oberhaus Creek	Oberhaus
9	Oberhaus Creek & Woodlawn	Oberhaus Creek	Oberhaus
10	Stevenson & Oberhaus Creek	Oberhaus Creek	Oberhaus
11	W. Maumee & Graceway	Southside	Maumee River
14	Riverview Ave. & Wayne Park	Front	Maumee River

10. NPDES permit No 2PD00000\*LD included one plant bypass (Outfall 602) and two collection system overflows (Outfalls numbered 2PD00000002 and 2PD00000005) located in separate sanitary sewer areas. Respondent has documented several overflow events at these SSOs. The following list indicates the number of documented overflow events at the plant bypass and at each of these SSOs between July 1994 and July 1999 (with the exception of November 1998). It should be noted that the WWTP was under construction from July 1997 until October 1998.

contracts, initiating and completing construction, and attaining compliance with the terms of the NPDES permit.

Three copies of the General Plan shall be submitted to the Ohio EPA Northwest District Office. During the planning process, Ohio EPA will evaluate proposed measures for approval of the overall concept and the use of facilities included in the proposal. Ohio EPA will authorize the installation of proposed facilities through the issuance of a Permit to Install upon submission of detailed plans.

8. Within 36 months from the first day of January immediately following the effective date of these Orders, Respondent shall develop and submit a Combined Sewer System Long Term Control Plan. The goal of the plan is that discharges from combined-sewer-overflows shall not cause or significantly contribute to violations of water quality standards, including toxicity impacts on stream biota, or impairment of designated uses of the waters of the state, including, without limitation, the Maumee River and Oberhaus Creek. The plan shall address, at a minimum, the following:

- a. Respondent shall characterize its collection system and overflows using the tools of monitoring and modeling. A monitoring program will be proposed that provides adequate data to characterize and model the collection system and overflows; supports development and implementation of the minimum control measures; supports development and implementation of a long-term control plan; and allows the effectiveness of control measures to be evaluated.
- b. Respondent shall identify CSO discharges to State Resource Waters (OAC 3745-1-05), Bathing Waters (OAC 3745-1-07(B)(4)), and all surface waters within 500 yards of an existing public water supply intake and designate these discharges as the highest priority for elimination, relocation or treatment. Overflows to these waters shall be eliminated or relocated whenever physically and economically achievable, except when this would cause unacceptable water quality impacts elsewhere in the system. If elimination or relocation is not possible, then treatment must be provided that will result in attainment of water quality standards and designated uses.
- c. Respondent shall identify CSO discharges to waters of the state, including small, accessible urban streams, where there is a high probability for contact recreation, and develop controls to ensure that these waters attain the applicable water quality standards for bacteria. The potential for human health impacts, public input on the recreational value of the streams, and financial considerations should be used to prioritize controls for these streams.
- d. Respondent shall develop and implement a significant notification program that informs the public of the possible health and environmental impacts associated with CSOs, and advises against contact recreation when elevated bacteria



levels may endanger public health.

- e. Respondent shall consider either the "presumption" or the "demonstration" approach included in U.S. EPA's National Combined Sewer Overflow Policy (April 19, 1994). Elimination of overflows shall always be evaluated as a control option and shall be implemented if it is cost effective, economically achievable, and does not cause new or significantly increased overflows elsewhere in the system.
- f. As part of CSO control, Ohio EPA expects communities to identify combined and separate sewered areas and to minimize the impact of separate sanitary flows on CSO discharges. Steps to consider include: using express sewers to route sanitary flows around combined sewer areas and reducing infiltration and inflow into the separate sewers. Communities also should consider ways to reduce storm water flow into combined sewers. Steps to consider include: diverting storm water away from the combined system (e.g, by constructing retention basins); removing inflow, such as roof drains); and using catch basin flow restriction.
- g. Respondent shall conduct cost/performance analyses to determine where the increment of CSO abatement diminishes compared to the increased costs.
- h. Respondent shall propose revisions to the Combined Sewer System Operational Plan necessary to implement long term controls.
- i. Respondent shall consider sanitary sewer separation projects, the elimination of CSO outfalls, the addition of primary treatment and disinfection capacity, and other cost effective measures, such as retention basins, for the purpose of eliminating, or increasing the treatment of, wet weather flows. During the planning process, Ohio EPA will evaluate proposed measures for approval of the overall concept and the use of facilities included in the proposal. Ohio EPA will authorize the installation of proposed facilities through the issuance of a Permit to Install upon submission of detailed plans.
- j. Respondent shall propose an implementation schedule based on consideration of the following: the relative magnitude of adverse impacts on water quality standards and designated uses, the community's financial capability, the relative cost/performance evaluations of individual projects, the priorities developed through public participation, and previous efforts to control CSOs.
- k. Respondent shall give the public affected by the development and implementation of the CSO Long Term Control Plan the opportunity to actively participate in the process. This includes participation in the evaluation and selection of controls, in determining the value that the community places on recreation opportunities that are impacted by CSO discharges, and in setting

priorities for CSO control projects.

---

When the CSO Long Term Control Plan is approved by the Director of Ohio EPA, the implementation schedule included in the plan shall be incorporated by reference as part of Respondent's NPDES permit, or the NPDES permit may be modified to incorporate the approved implementation schedule.

9. Respondent shall pay to Ohio EPA the amount of twelve thousand dollars (\$12,000.00) in settlement of Ohio EPA claims for civil penalties, which may be assessed pursuant to Chapter 6111 of the Ohio Revised Code. This payment shall be made by tendering a certified check made payable to "Treasurer, State of Ohio" for the full amount within 30 days after the effective date of these Orders to the following address:

Vicki Galilei, Office of Fiscal Administration  
Ohio Environmental Protection Agency  
Lazarus Government Center  
P.O. Box 1049  
Columbus, Ohio 43216-1049

A photocopy of the check shall be made to Jim Vinch of Ohio EPA Legal.

10. All documents required to be delivered by Respondent pursuant to Orders 2,4,5,6, 7, 8 and 9 shall be deemed to be delivered as of the date that Respondent deposits such document in the mail, postage prepaid, to the following address:

Ohio Environmental Protection Agency  
Northwest District Office  
347 North Dunbridge Road  
Bowling Green, Ohio 43402  
(ATTN: Enforcement Group Leader)

#### OTHER APPLICABLE LAWS

All actions required to be taken pursuant to these Orders shall be undertaken in accordance with the requirements of all applicable local, state, and federal laws and regulations. Nothing in these Orders shall be construed as waiving or compromising in any way the applicability and enforcement of any other statutes or regulations applicable to Respondent's operation of its Facility.

### RESERVATION OF RIGHTS

These Orders do not prevent Ohio EPA from enforcing the terms of these Orders or from taking other administrative, legal, or equitable action as deemed appropriate and necessary, including seeking penalties against Respondent for noncompliance with these Orders or for violations identified in these Orders. These Orders do not prevent Ohio EPA from exercising its authority to require Respondent to perform additional activities pursuant to Chapter 6111 of the Ohio Revised Code or any other applicable law in the future. These Orders do not restrict the right of Respondent to raise any administrative, legal, or equitable claim or defense for any additional activities that Ohio EPA may seek to require of respondent. These Orders do not limit the authority of Ohio EPA to seek relief for violations not cited in these Orders.

### TERMINATION

The Respondent's obligations under these Orders shall be satisfied and terminate when Respondent demonstrates in writing, and certifies to the satisfaction of Ohio EPA that all obligations under these Orders have been performed, and the Chief of Ohio EPA's Division of Surface Water acknowledges in writing the termination of these Orders.

This certification shall be submitted by the Respondent to the Northwest District Office (Attention: DSW Enforcement Group Leader) and shall be signed by a responsible official of the City of Napoleon.

A responsible official is as defined in Ohio Administrative Code (OAC) 3745-33-03(D)(1) for a corporation, OAC 3745-33-03(D)(2) for a partnership, OAC 3745-33-03(D)(3) for a sole proprietorship, and OAC 3745-33-03(D)(4) for a municipal, state, or other public facility. The certification shall contain the following attestation:

*"I certify under the penalty of law that I have personally examined and am familiar with the information contained in or accompanying this certification, and based on my inquiry of those individuals immediately responsible for obtaining the information, I believe the information contained in or accompanying this certification is true, accurate, and complete. I am aware that there are significant penalties for submitting false information, including the possibility of fine or imprisonment."*

**WAIVER**

In order to resolve disputed claims, without admission of fact, violation or liability, Respondent agrees that these Orders are lawful and reasonable, that the schedules provided for compliance herein are reasonable, and the Respondent agrees to comply with these Orders. Ohio EPA specifically does not waive its right to pursue actions and civil penalties as set forth in the reservation of Rights paragraph of these ORDERS.

Respondent hereby waives the right to appeal the issuance, terms, and service of these Orders, and it hereby waives any and all rights it might have to seek judicial review of said Orders either in law or equity.

Notwithstanding the preceding, in the event that these Orders are appealed by any other party to the Environmental Review Appeals Commission, or any court, Respondent retains the right to intervene and participate in such appeal. In such event, respondent shall continue to comply with these Orders notwithstanding such appeal and intervention unless said Orders are stayed, vacated, or modified.

**SIGNATURE AUTHORITY**

Each undersigned representative of a signatory to these Orders certifies that he or she is fully authorized to enter into the terms and conditions of these Orders and to legally bind such signatory to this document.

**IT IS SO AGREED:**

City of Napoleon

BY: \_\_\_\_\_

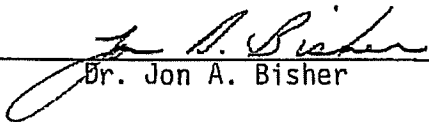
  
Dr. Jon A. Bisher

TITLE: City Manager

DATE: June 19, 2000

**IT IS SO ORDERED AND AGREED:**

Ohio Environmental Protection Agency

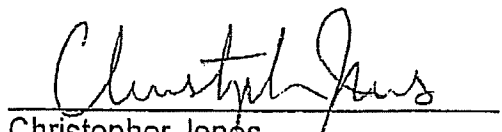
  
Christopher Jones

Director

DATE: 7-19-00

## ATTACHMENT A

### MONITORING REQUIREMENTS FOR OUTFALLS 002, 005, 5, 7, 9, 10, 11, and 14:

CHARACTERISTIC REQUIREMENT				MONITORING
<u>Code</u>	<u>Units</u>	<u>Parameter</u>	<u>Frequency</u>	<u>Sample Type</u>
	Reporting			Measurement
00530	mg/l	Suspended Solids	1/Month	Grab
50050	MGD	Flow	When Discharging	Daily Estimate
80082	mg/l	CBOD <sub>5</sub>	1/Month	Grab
80998	No./Month	Occurrences	When Discharging	Estimate
80999	Hours	Duration	When Discharging	Daily Estimate
	SU	pH	1/month	Grab
	mg/l	Dissolved Oxygen	1/month	Grab

Respondent shall set up a rotating schedule to sample at least three (3) outfalls during each storm event. Samples should be collected during the first 30 minutes of discharge or as soon as possible. Data for the number of Occurrences per day, the daily Duration and the total daily Flow may be estimated.

For days when there are no overflow events, data for parameters which require laboratory analysis should be reported as "AH" and an explanation of "No Discharge" entered in the "Additional Remarks" section. Also, on such days Zero should be reported for occurrences, duration, and flow.

Monitoring data shall be submitted for each month when discharge occurs. When discharge occurs the monthly monitoring report shall be attached to the normal monthly report form.

Application No. OH0020893

Issue Date: August 14, 2019

Effective Date: September 1, 2019

Expiration Date: August 31, 2024

Ohio Environmental Protection Agency  
Authorization to Discharge Under the  
National Pollutant Discharge Elimination System

In compliance with the provisions of the Federal Water Pollution Control Act, as amended (33 U.S.C. 1251 et. seq., hereinafter referred to as the "Act"), and the Ohio Water Pollution Control Act (Ohio Revised Code Section 6111),

City of Napoleon

is authorized by the Ohio Environmental Protection Agency, hereinafter referred to as "Ohio EPA," to discharge from the Napoleon Wastewater Treatment Plant wastewater treatment works located at 735 East Washington Street, Napoleon, Ohio, Henry County and discharging to the Maumee River in accordance with the conditions specified in Parts I, II, and III of this permit.

This permit is conditioned upon payment of applicable fees as required by Section 3745.11 of the Ohio Revised Code.

This permit and the authorization to discharge shall expire at midnight on the expiration date shown above. In order to receive authorization to discharge beyond the above date of expiration, the permittee shall submit such information and forms as are required by the Ohio EPA no later than 180 days prior to the above date of expiration.

---

Laurie A. Stevenson  
Director

Total Pages: 55

Part I, A. - INTERIM EFFLUENT LIMITATIONS AND MONITORING REQUIREMENTS

1. During the period beginning on the effective date of this permit and lasting until the end of the 54th month after the effective date, the permittee is authorized to discharge in accordance with the following limitations and monitoring requirements from the following outfall: 2PD00000001. See Part II, OTHER REQUIREMENTS, for locations of effluent sampling.

Table - Final Outfall - 001 - Initial - 001 - Initial

Effluent Characteristic	Discharge Limitations				Monitoring Requirements			
	Parameter	Concentration	Specified Units	Loading* kg/day	Measuring Frequency	Sampling Type	Monitoring Months	
00010 - Water Temperature - C	-	-	-	-	1/Day	Maximum Indicating Thermometer	All	
00300 - Dissolved Oxygen - mg/l	-	2.0	-	-	1/Day	Multiple Grab	Winter	
00300 - Dissolved Oxygen - mg/l	-	5.0	-	-	1/Day	Multiple Grab	Summer	
00530 - Total Suspended Solids - mg/l	-	45	30	426	3/Week	24hr Composite	All	
00552 - Oil and Grease, Hexane Extr Method - mg/l	10	-	-	-	1 / 2 Weeks	Grab	All	
00610 - Nitrogen, Ammonia (NH3) - mg/l	-	27	18	255	3/Week	24hr Composite	Dec - May	
00610 - Nitrogen, Ammonia (NH3) - mg/l	-	5.0	3.3	47.3	3/Week	24hr Composite	Oct - Nov	
00610 - Nitrogen, Ammonia (NH3) - mg/l	-	2.4	1.6	22.7	3/Week	24hr Composite	June - Sep	
00625 - Nitrogen Kjeldahl, Total - mg/l	-	-	-	-	1/Month	24hr Composite	All	
00630 - Nitrite Plus Nitrate, Total - mg/l	-	-	-	-	1/Month	24hr Composite	All	
00665 - Phosphorus, Total (P) - mg/l	-	1.5	1.0	14	1/Week	24hr Composite	All	
00671 - Orthophosphate, Dissolved (as P) - mg/l	-	-	-	-	1/Month	Grab	All	
01074 - Nickel, Total Recoverable - ug/l	-	-	-	-	1/Quarter	24hr Composite	Quarterly	
01094 - Zinc, Total Recoverable - ug/l	-	-	-	-	1/Quarter	24hr Composite	Quarterly	
01113 - Cadmium, Total Recoverable - ug/l	-	-	-	-	1/Quarter	24hr Composite	Quarterly	
01114 - Lead, Total Recoverable - ug/l	-	-	-	-	1/Quarter	24hr Composite	Quarterly	
01118 - Chromium, Total Recoverable - ug/l	-	-	-	-	1/Quarter	24hr Composite	Quarterly	
01119 - Copper, Total Recoverable - ug/l	-	-	-	-	1/Month	24hr Composite	All	

<u>Effluent Characteristic</u>		<u>Discharge Limitations</u>			<u>Monitoring Requirements</u>		
Parameter	Concentration	Specified Units		Loading* kg/day	Measuring Frequency	Sampling Type	Monitoring Months
		Maximum	Minimum				
01220 - Chromium, Dissolved Hexavalent - ug/l	-	-	-	-	1/Quarter	Grab	Quarterly
31648 - E. coli - #/100 ml	-	284	126	-	3/Week	Grab	Summer
46529 - Rainfall in Inches - Inches	-	-	-	-	1/Day	Maximum	All
50050 - Flow Rate - MGD	-	-	-	-	1/Day	Continuous	All
50092 - Mercury, Total (Low Level) - ng/l	1700	-	4.2	0.016	1/Month	Grab	All
61425 - Acute Toxicity, Ceriodaphnia dubia - TUa	-	-	-	-	2/Year	24hr Composite	May and July
61426 - Chronic Toxicity, Ceriodaphnia dubia - TUc	-	-	-	-	2/Year	24hr Composite	May and July
61427 - Acute Toxicity, Pimephales promelas - TUa	-	-	-	-	1/Year	24hr Composite	July
61428 - Chronic Toxicity, Pimephales promelas - TUc	-	-	-	-	1/Year	24hr Composite	July
61941 - pH, Maximum - S.U.	9.0	-	-	-	1/Day	Multiple Grab	All
61942 - pH, Minimum - S.U.	-	6.5	-	-	1/Day	Multiple Grab	All
70300 - Residue, Total Filterable - mg/l	-	-	-	-	1/Month	24hr Composite	All
79858 - Plant Core Person ID - Number	-	-	-	-	When Disch.	Grab	All
79859 - Collection System Visit Core Person ID - Number	-	-	-	-	When Disch.	Grab	All
80082 - CBOD 5 day - mg/l	-	23	15	-	3/Week	24hr Composite	Summer
80082 - CBOD 5 day - mg/l	-	40	25	379	3/Week	24hr Composite	Winter
82073 - Plant Time In - Time (HHMM)	-	-	-	-	When Disch.	Grab	All
82074 - Plant Time Out - Time (HHMM)	-	-	-	-	When Disch.	Grab	All

Notes for station 2PD00000001:

- \* Effluent loadings based on average design flow of 2.5 MGD.
- a. Mercury - See Part II, Items X, Y, and Z.
- b. Orthophosphate - See Part II, Item W.
- c. Biomonitoring - See Part I,C, Item A and Part II, Items AA, AB, and AE.
- d. Semi-annual monitoring for C. dubia chronic toxicity shall be conducted in January and July.



Part I, A. - FINAL EFFLUENT LIMITATIONS AND MONITORING REQUIREMENTS

2. During the period beginning 55 months after the effective date of this permit and lasting until the expiration date, the permittee is authorized to discharge in accordance with the following limitations and monitoring requirements from the following outfall: 2PD000000001. See Part II, OTHER REQUIREMENTS, for locations of effluent sampling.

Table - Final Outfall - 001 - Final

Effluent Characteristic Parameter	Discharge Limitations				Monitoring Requirements			
	Maximum Concentration Minimum	Specified Units	Loading* kg/day	Monitoring Months	Measuring Frequency	Sampling Type	Monitoring Months	
00010 - Water Temperature - C	-	-	-	-	1/Day	Maximum Indicating Thermometer	All	
00300 - Dissolved Oxygen - mg/l	-	5.0	-	-	1/Day	Multiple Grab	Summer	
00300 - Dissolved Oxygen - mg/l	-	2.0	-	-	1/Day	Multiple Grab	Winter	
00530 - Total Suspended Solids - mg/l	-	45	426	284	3/Week	24hr Composite	All	
00552 - Oil and Grease, Hexane Extr Method - mg/l	10	-	-	-	1 / 2 Weeks	Grab	All	
00610 - Nitrogen, Ammonia (NH3) - mg/l	-	5.0	47.3	31.2	3/Week	24hr Composite	Oct - Nov	
00610 - Nitrogen, Ammonia (NH3) - mg/l	-	27	255	170	3/Week	24hr Composite	Dec - May	
00610 - Nitrogen, Ammonia (NH3) - mg/l	-	2.4	22.7	15.1	3/Week	24hr Composite	June - Sep	
00625 - Nitrogen Kjeldahl, Total - mg/l	-	-	-	-	1/Month	24hr Composite	All	
00630 - Nitrite Plus Nitrate, Total - mg/l	-	-	-	-	1/Month	24hr Composite	All	
00665 - Phosphorus, Total (P) - mg/l	-	1.5	14	9.47	1/Week	24hr Composite	All	
00671 - Orthophosphate, Dissolved (as P) - mg/l	-	-	-	-	1/Month	Grab	All	
01074 - Nickel, Total Recoverable - ug/l	-	-	-	-	1/Quarter	24hr Composite	Quarterly	
01094 - Zinc, Total Recoverable - ug/l	-	-	-	-	1/Quarter	24hr Composite	Quarterly	
01113 - Cadmium, Total Recoverable - ug/l	-	-	-	-	1/Quarter	24hr Composite	Quarterly	
01114 - Lead, Total Recoverable - ug/l	-	-	-	-	1/Quarter	24hr Composite	Quarterly	
01118 - Chromium, Total Recoverable - ug/l	-	-	-	-	1/Quarter	24hr Composite	Quarterly	
01119 - Copper, Total Recoverable - ug/l	-	-	-	-	1/Month	24hr Composite	All	

<u>Effluent Characteristic</u>		<u>Discharge Limitations</u>				<u>Monitoring Requirements</u>				
Parameter	Maximum Minimum	Concentration Specified	Weekly	Monthly	Daily	Weekly	Monthly	Measuring Frequency	Sampling Type	Monitoring Months
01220 - Chromium, Dissolved Hexavalent - ug/l	-	-	-	-	-	-	-	1/Quarter	Grab	Quarterly
31648 - E. coli - #/100 ml	-	284	-	126	-	-	-	3/Week	Grab	Summer
46529 - Rainfall in Inches - Inches	-	-	-	-	-	-	-	1/Day	Maximum	All
50050 - Flow Rate - MGD	-	-	-	-	-	-	-	1/Day	Continuous	All
50092 - Mercury, Total (Low Level) - ng/l	1700	-	-	4.2	0.016	-	0.00004	1/Month	Grab	All
61425 - Acute Toxicity, Ceriodaphnia dubia - TUa	-	-	-	-	-	-	-	2/Year	24hr Composite	Semi-annual
61426 - Chronic Toxicity, Ceriodaphnia dubia - TUc	2.21	-	-	-	-	-	-	2/Year	24hr Composite	Semi-annual
61427 - Acute Toxicity, Pimephales promelas - TUa	-	-	-	-	-	-	-	1/Year	24hr Composite	July
61428 - Chronic Toxicity, Pimephales promelas - TUc	-	-	-	-	-	-	-	1/Year	24hr Composite	July
61941 - pH, Maximum - S.U.	9.0	-	-	-	-	-	-	1/Day	Multiple Grab	All
61942 - pH, Minimum - S.U.	-	6.5	-	-	-	-	-	1/Day	Multiple Grab	All
70300 - Residue, Total Filterable - mg/l	-	-	-	-	-	-	-	1/Month	24hr Composite	All
79858 - Plant Core Person ID - Number	-	-	-	-	-	-	-	When Disch.	Grab	All
79859 - Collection System Visit Core Person ID - Number	-	-	-	-	-	-	-	When Disch.	Grab	All
80082 - CBOD 5 day - mg/l	-	23	15	-	-	216	142	3/Week	24hr Composite	Summer
80082 - CBOD 5 day - mg/l	-	40	25	-	-	379	237	3/Week	24hr Composite	Winter
82073 - Plant Time In - Time (HHMM)	-	-	-	-	-	-	-	When Disch.	Grab	All
82074 - Plant Time Out - Time (HHMM)	-	-	-	-	-	-	-	When Disch.	Grab	All

Notes for station 2PD00000001:

\* Effluent loadings based on average design flow of 2.5 MGD.

- a. Mercury - See Part II, Items X, Y, and Z.
- b. Orthophosphate - See Part II, Item W.
- c. Biomonitoring - See Part I,C, Item A and Part II, Items AA, AB, and AE.
- d. Semi-annual monitoring for C. dubia chronic toxicity shall be conducted in January and July.

Part I, A. - FINAL EFFLUENT LIMITATIONS AND MONITORING REQUIREMENTS

3. During the period beginning on the effective date of this permit and lasting until the expiration date, the permittee is authorized to discharge in accordance with the following limitations and monitoring requirements from the following outfall: 2PD00000603. See Part II, OTHER REQUIREMENTS, for locations of effluent sampling.

Table - Internal Monitoring Station - 603 - Final

Effluent Characteristic Parameter	Discharge Limitations				Monitoring Requirements		
	Concentration Maximum Minimum	Specified Weekly	Units Monthly	Loading* Daily	Measuring Frequency	Sampling Type	Monitoring Months
00530 - Total Suspended Solids - mg/l	-	-	-	-	When Disch.	Grab	All
50047 - Flow, Peak Rate - MGD	-	-	-	-	When Disch.	Continuous	All
74062 - Overflow Occurrence - No./Month	-	-	-	-	When Disch.	Total	All
74063 - Overflow Volume - Million Gallons	-	-	-	-	When Disch.	24hr Total	All
80082 - CBOD 5 day - mg/l	-	-	-	-	When Disch.	Grab	All

NOTES for Station Number 2PD00000603, the EQ basin overflow prior to disinfection:

- a. Data for peak flow rate, overflow occurrence, and overflow duration may be estimated if a measuring device is not available.
- b. A Discharge Monitoring Report (DMR) for this station must be submitted every month.
- c. Monitoring and sampling shall be conducted and reported on each day that there is a discharge through this station.
- d. If there are no discharges during the entire month, select the "No Discharge" check box on the data entry form and PIN the eDMR.
- e. Overflow Occurrence: If a discharge from this station occurs intermittently during a day, starting and stopping several times, report "1" for that day. If a discharge from this station occurs on more than one day but is the result of a continuing precipitation event, it should be counted as one occurrence: Report "1" on the first day of the discharge.

Part I, B. - CSO MONITORING LIMITATIONS AND MONITORING REQUIREMENTS

1. CSO Monitoring. During the period beginning on the effective date of this permit and lasting until the expiration date, the permittee shall monitor at Station Numbers 2PD000000003, 2PD000000004, 2PD000000006, 2PD000000010, and 2PD000000011, and report to the Ohio EPA in accordance with the following table. See Part II, OTHER REQUIREMENTS, for location of CSO sampling.

Table - CSO Monitoring - 003 - Final

Effluent Characteristic Parameter	Discharge Limitations				Monitoring Requirements				
	Concentration Maximum Minimum	Specified Units	Monthly	Daily	Loading* Weekly	kg/day Monthly	Measuring Frequency	Sampling Type	Monitoring Months
00530 - Total Suspended Solids - mg/l	-	-	-	-	-	-	When Disch.	Grab	All
74062 - Overflow Occurrence - No./Month	-	-	-	-	-	-	When Disch.	Total	All
74063 - Overflow Volume - Million Gallons	-	-	-	-	-	-	When Disch.	24hr Total	All
80082 - CBOD 5 day - mg/l	-	-	-	-	-	-	When Disch.	Grab	All

NOTES for Station Number 2PD000000003, 2PD000000004, 2PD000000006, 2PD000000010, and 2PD000000011:

- a. Subject to the terms and conditions of this permit, including the General Effluent Limitations in Part III, Item 2, the permittee is authorized to discharge from this station only during wet weather periods when the flow in the sewer system exceeds the capacity of the sewer system.
- b. A Discharge Monitoring Report (DMR) for this station must be submitted every month.
- c. If this station is not monitored during a particular month: (1) Leave the data area blank; (2) Enter "Monitoring not required" in the Remarks section; and (3) PIN the eDMR.
- d. If this station is monitored during a particular month and there are no discharges during the entire month, select the "No Discharge" check box on the data entry form and PIN the eDMR.
- e. Data for Overflow Occurrence and Overflow Volume may be estimated if a measuring device is not available.
- f. Overflow Occurrences: If a discharge from this station occurs intermittently during a day, starting and stopping several times, count "1" occurrence for that day. If a discharge from this station occurs on more than one day but is the result of a continuing precipitation event, it should be counted as one occurrence. Report total occurrences for the month on Day 1 of the DMR.

g. Overflow Volume shall be reported on each day there is a discharge through this station. Data for total suspended solids and CBOD5 shall be reported once per occurrence.

h. CSOs - See Part II, Items C, D, and E.

Part I, B. - SSO MONITORING EFFLUENT LIMITATIONS AND MONITORING REQUIREMENTS

2. SSO Monitoring. During the period beginning on the effective date of this permit and lasting until the expiration date, the permittee shall monitor at Station Number 2PD00000300, and report to the Ohio EPA in accordance with the following table. See Part II, OTHER REQUIREMENTS, for location of sampling.

Table - SSO Monitoring - 300 - Final

Effluent Characteristic	Discharge Limitations				Monitoring Requirements				
	Parameter	Concentration Maximum	Specified Units	Loading* kg/day	Measuring Frequency	Sampling Type	Monitoring Months		
74062 - Overflow Occurrence - No./Month	-	-	Monthly	Daily	Weekly	Monthly	1/Month	Total	All

NOTES for Station Number 2PD00000300:

- a. A sanitary sewer overflow is an overflow, spill, release, or diversion of wastewater from a sanitary sewer system. Although the above table indicates that the Measuring Frequency for Overflow Occurrence is 1/Month, the intent of that provision is to specify a reporting frequency for Overflow Occurrence, not a monitoring frequency. The monitoring requirement under this permit is that these overflows shall be monitored on each day when they discharge. Only sanitary sewer overflows that enter waters of the state, either directly or through a storm sewer or other conveyance, must be reported under this monitoring station.
- b. For the purpose of counting occurrences, each location on the sanitary sewer system where there is an overflow, spill, release, or diversion of wastewater on a given day that enters waters of the state is counted as one occurrence. For example, if on a given day overflows occur from a manhole at one location and from a damaged pipe at another location and they both enter waters of the state, record two occurrences for that day. If overflows from both locations continue on the following day, record two occurrences for the following day. At the end of the month, total the daily occurrences and report this number on Day 1 of the DMR. If there are no overflows during the entire month, report "zero" (0).
- c. All sanitary sewer overflows are prohibited.
- d. For this station, report all system-wide sanitary sewer overflow occurrences other than those reported under stations 2PD00000302 and 2PD00000303.
- e. See Part II, Items H and I.

Part I, B. - SSO MONITORING EFFLUENT LIMITATIONS AND MONITORING REQUIREMENTS

3. SSO Monitoring. During the period beginning on the effective date of this permit and lasting until the expiration date, the permittee shall monitor at Station Number 2PD00000302, and report to the Ohio EPA in accordance with the following table. See Part II, OTHER REQUIREMENTS, for location of sampling.

Table - SSO Monitoring - 302 - Final

Effluent Characteristic	Discharge Limitations				Monitoring Requirements			
	Parameter	Concentration Minimum	Specified Units	Loading* kg/day	Measuring Frequency	Sampling Type	Monitoring Months	
74062 - Overflow Occurrence - No./Month	-	-	-	-	1/Month	Total	All	
74063 - Overflow Volume - Million Gallons	-	-	-	-	1/Month	24hr Total	All	

NOTES for Station Number 2PD00000302:

- a. A sanitary sewer overflow is an overflow, spill, release, or diversion of wastewater from a sanitary sewer system. Although the above table indicates that the Measuring Frequency for Overflow Occurrence is 1/Month, the intent of that provision is to specify a reporting frequency for Overflow Occurrence, not a monitoring frequency. The monitoring requirement under this permit is that these overflows shall be monitored on each day when they discharge. Only sanitary sewer overflows that enter waters of the state, either directly or through a storm sewer or other conveyance, must be reported under this monitoring station.
- b. For the purpose of counting occurrences, each location on the sanitary sewer system where there is an overflow, spill, release, or diversion of wastewater on a given day that enters waters of the state is counted as one occurrence. For example, if on a given day overflows occur from a manhole at one location and from a damaged pipe at another location and they both enter waters of the state, record two occurrences for that day. If overflows from both locations continue on the following day, record two occurrences for the following day. At the end of the month, total the daily occurrences and report this number on Day 1 of the DMR. If there are no overflows during the entire month, report "zero" (0).
- c. All sanitary sewer overflows are prohibited.
- d. See Part II, Items H and I.

Part I, B. - SSO MONITORING EFFLUENT LIMITATIONS AND MONITORING REQUIREMENTS

4. SSO Monitoring. During the period beginning on the effective date of this permit and lasting until the expiration date, the permittee shall monitor at Station Number 2PD00000303, and report to the Ohio EPA in accordance with the following table. See Part II, OTHER REQUIREMENTS, for location of sampling.

Table - SSO Monitoring - 303 - Final

Effluent Characteristic	Discharge Limitations				Monitoring Requirements			
	Parameter	Concentration Minimum	Specified Units	Loading* kg/day	Measuring Frequency	Sampling Type	Monitoring Months	
74062 - Overflow Occurrence - No./Month	-	-	-	-	1/Month	Total	All	
74063 - Overflow Volume - Million Gallons	-	-	-	-	1/Month	24hr Total	All	

NOTES for Station Number 2PD00000303:

a. A sanitary sewer overflow is an overflow, spill, release, or diversion of wastewater from a sanitary sewer system. Although the above table indicates that the Measuring Frequency for Overflow Occurrence is 1/Month, the intent of that provision is to specify a reporting frequency for Overflow Occurrence, not a monitoring frequency. The monitoring requirement under this permit is that these overflows shall be monitored on each day when they discharge. Only sanitary sewer overflows that enter waters of the state, either directly or through a storm sewer or other conveyance, must be reported under this monitoring station.

b. For the purpose of counting occurrences, each location on the sanitary sewer system where there is an overflow, spill, release, or diversion of wastewater on a given day that enters waters of the state is counted as one occurrence. For example, if on a given day overflows occur from a manhole at one location and from a damaged pipe at another location and they both enter waters of the state, record two occurrences for that day. If overflows from both locations continue on the following day, record two occurrences for the following day. At the end of the month, total the daily occurrences and report this number on Day 1 of the DMR. If there are no overflows during the entire month, report "zero" (0).

c. All sanitary sewer overflows are prohibited.

d. See Part II, Items H and I.



Part I, B. - SLUDGE MONITORING REQUIREMENTS

5. Sludge Monitoring. During the period beginning on the effective date of this permit and lasting until the expiration date, the permittee shall monitor the treatment works' final sludge at Station Number 2PD00000581, and report to the Ohio EPA in accordance with the following table. See Part II, OTHER REQUIREMENTS, for location of sludge sampling.

Table - Sludge Monitoring - 581 - Final

Effluent Characteristic	Concentration			Discharge Limitations			Monitoring Requirements				
	Maximum	Minimum	Specified Units	Weekly	Monthly	Daily	Weekly	Monthly	Measuring Frequency	Sampling Type	Monitoring Months
00611 - Ammonia (NH3) In Sludge - mg/kg	-	-	-	-	-	-	-	-	1/Quarter	Composite	Quarterly - Alt.
00627 - Nitrogen Kjeldahl, Total In Sludge - mg/kg	-	-	-	-	-	-	-	-	1/Quarter	Composite	Quarterly - Alt.
00668 - Phosphorus, Total In Sludge - mg/kg	-	-	-	-	-	-	-	-	1/Quarter	Composite	Quarterly - Alt.
00938 - Potassium In Sludge - mg/kg	-	-	-	-	-	-	-	-	1/Quarter	Composite	Quarterly - Alt.
01003 - Arsenic, Total In Sludge - mg/kg	75	-	-	-	-	-	-	-	1/Quarter	Composite	Quarterly - Alt.
01028 - Cadmium, Total In Sludge - mg/kg	85	-	-	-	-	-	-	-	1/Quarter	Composite	Quarterly - Alt.
01043 - Copper, Total In Sludge - mg/kg	4300	-	-	-	-	-	-	-	1/Quarter	Composite	Quarterly - Alt.
01052 - Lead, Total In Sludge - mg/kg	840	-	-	-	-	-	-	-	1/Quarter	Composite	Quarterly - Alt.
01068 - Nickel, Total In Sludge - mg/kg	420	-	-	-	-	-	-	-	1/Quarter	Composite	Quarterly - Alt.
01093 - Zinc, Total In Sludge - mg/kg	7500	-	-	-	-	-	-	-	1/Quarter	Composite	Quarterly - Alt.
01148 - Selenium, Total In Sludge - mg/kg	100	-	-	-	-	-	-	-	1/Quarter	Composite	Quarterly - Alt.
31641 - Fecal Coliform in Sludge - MPN/G	2000000	-	-	-	-	-	-	-	1/Quarter	Composite	Quarterly - Alt.
51129 - Sludge Fee Weight - dry tons	-	-	-	-	-	-	-	-	1/Quarter	Total	Quarterly - Alt.
70316 - Sludge Weight - Dry Tons	-	-	-	-	-	-	-	-	1/Quarter	Total	Quarterly - Alt.
71921 - Mercury, Total In Sludge - mg/kg	57	-	-	-	-	-	-	-	1/Quarter	Composite	Quarterly - Alt.

Effluent Characteristic Parameter	Discharge Limitations				Monitoring Requirements			
	Concentration Specified Maximum Minimum	Weekly	Monthly	Daily	Loading* kg/day	Measuring Frequency	Sampling Type	Monitoring Months
78465 - Molybdenum In Sludge - mg/kg	75	-	-	-	-	1/Quarter	Composite	Quarterly - Alt.

NOTES for Station Number 2PD00000581:

- a. Monitoring is required when sewage sludge is removed from the permittee's facility for application to the land. The monitoring data shall be reported on the March, June, September and December Discharge Monitoring Report (DMR). The monitoring data can be collected at any time during the reporting period.
- b. Metal analysis must be completed during each reporting period whether or not sewage sludge is removed from the facility and applied to the land. Alternatively, the number of composite samples collected and reported prior to the next land application event shall be increased to account for the reporting period(s) in which land application did not occur. If all accumulated sewage sludge has been removed and hauled to a landfill, incinerated or transferred to another NPDES permit holder, then the metal analysis is not required.
- c. If no sewage sludge is removed from the facility during the reporting period, enter the results for the metal analysis on the DMR and enter "0" for sludge weight and sludge fee weight.
- d. If no sewage sludge is removed from the facility during the reporting period and no metal analysis is completed during the reporting period, select the "No Discharge" check box on the data entry form and PIN the eDMR.
- e. If metal analysis has not been completed previously during each reporting period: when sewage sludge is removed from the facility all metal analysis results shall be reported on the applicable DMR by entering the separate results on different days within the DMR. For example, if no sewage sludge has been removed from the facility for a full calendar year, and quarterly monitoring is required by the permit, then five (four from the previous year and one for the current monitoring period) separate composite samples of the sewage sludge are required to be collected and analyzed for metals prior to removal from the facility. The first sample result may be entered on the first day of the DMR, the second result on the second day of the DMR, and so on. A note may then be added to indicate the actual day(s) when the samples were collected.
- f. It is recommended that composite samples of the sewage sludge be collected and analyzed close enough to the time of land application to be reflective of the sludge's current quality, but not so close that the results of the analysis are not available prior to land applying the sludge.

- g. The permittee shall maintain the appropriate records on site to verify that the requirements of Pathogen Reduction and Vector Attraction Reduction have been met.
- h. Units of mg/kg are on a dry weight basis.
- i. Sludge weight is a calculated total for the year. To convert from gallons of liquid sewage sludge to dry tons of sewage sludge: dry tons = gallons x 8.34 (lbs/gallon) x 0.0005 (tons/lb) x decimal fraction total solids.
- j. Sludge free weight means sludge weight, in dry U.S. tons, excluding any admixtures such as liming material or bulking agents.
- k. See Part II, Items R, S, T, and U.
- l. To sample for fecal coliform, the treatment plant should collect and analyze a grab sample every other day over a two week period for a total of seven grab samples when practical. Each of the grab samples shall be analyzed independently to determine the MPN/g of fecal coliform in the individual sample. The geometric mean of those seven results shall be reported on the DMR. Each fecal coliform sample must be delivered to the analytical lab within six hours after the sample has been collected, in accordance with the requirements for Part 9221 E. or part 9222 D., "Standard Methods for the Examination of Water and Wastewater". This process must be completed prior to sewage sludge being removed from the treatment facility.

Part I, B. - SLUDGE MONITORING REQUIREMENTS

6. Sludge Monitoring. During the period beginning on the effective date of this permit and lasting until the expiration date, the permittee shall monitor the treatment works' final sludge at Station Number 2PD00000586, and report to the Ohio EPA in accordance with the following table. See Part II, OTHER REQUIREMENTS, for location of sludge sampling.

Table - Sludge Monitoring - 586 - Final

Effluent Characteristic	Discharge Limitations				Monitoring Requirements				
	Concentration Specified	Units	Loading* kg/day	Measuring Frequency	Sampling Type	Monitoring Months	1/Year	Total	
Parameter	Maximum	Minimum	Weekly	Monthly	Daily	Weekly	Monthly	1/Year	December
51129 - Sludge Fee Weight - dry tons	-	-	-	-	-	-	-	-	December

NOTES for Station Number 2PD00000586:

- a. Monitoring is required when sewage sludge is removed from the permittee's facility for disposal in a solid waste landfill. The total Sludge Fee Weight of sewage sludge disposed of in a solid waste landfill for the entire year shall be reported on the December Discharge Monitoring Report (DMR).
- b. If no sewage sludge is removed from the Permittee's facility for disposal in a solid waste landfill during the year, select the "No Discharge" check box on the data entry form and PIN the eDMR.
- c. Sludge fee weight means sludge weight, in dry U.S. tons, excluding any admixtures such as liming material or bulking agents.
- d. See Part II, Items R, S, T, and U.

Part I, B. - SLUDGE MONITORING REQUIREMENTS

7. Sludge Monitoring. During the period beginning on the effective date of this permit and lasting until the expiration date, the permittee shall monitor the treatment works' final sludge at Station Number 2PD0000588, and report to the Ohio EPA in accordance with the following table. See Part II, OTHER REQUIREMENTS, for location of sludge sampling.

Table - Sludge Monitoring - 588 - Final

Effluent Characteristic	Discharge Limitations				Monitoring Requirements			
	Parameter	Concentration Maximum	Specified Units	Loading* kg/day	Measuring Frequency	Sampling Type	Monitoring Months	Total
70316 - Sludge Weight - Dry Tons	-	-	-	-	1/Year		December	

NOTES for Station Number 2PD00000588:

- a. Monitoring is required when sewage sludge is removed from the permittee's facility for transfer to another NPDES permit holder. The total sludge weight or sludge volume transferred to another NPDES permit holder for the entire year shall be reported on the December Discharge Monitoring Report (DMR).
- b. If no sewage sludge is removed from the Permittee's facility for transfer to another NPDES permit holder during the year, select the "No Discharge" check box on the data entry form and PIN the eDMR.
- c. Sludge weight is a calculated total for the year. To convert from gallons of liquid sewage sludge to dry tons of sewage sludge: dry tons = gallons x 8.34 (lbs/gallon) x 0.0005 (tons/lb) x decimal fraction total solids.
- d. See Part II, Items R, S, T, and U.

Part I, B. - INFLUENT MONITORING REQUIREMENTS

8. Influent Monitoring. During the period beginning on the effective date of this permit and lasting until the expiration date, the permittee shall monitor the treatment works' influent wastewater at Station Number 2PD00000601, and report to the Ohio EPA in accordance with the following table. Samples of influent used for determination of net values or percent removal must be taken the same day as those samples of effluent used for that determination. See Part II, OTHER REQUIREMENTS, for location of influent sampling.

Table - Influent Monitoring - 601 - Final

Effluent Characteristic	Discharge Limitations				Monitoring Requirements				
	Concentration Maximum	Specified Units	Monthly	Daily	Loading* kg/day Weekly	Monthly	Measuring Frequency	Sampling Type	Monitoring Months
00530 - Total Suspended Solids - mg/l	-	-	-	-	-	-	3/Week	24hr Composite	All
00665 - Phosphorus, Total (P) - mg/l	-	-	-	-	-	-	1/Week	24hr Composite	All
01074 - Nickel, Total Recoverable - ug/l	-	-	-	-	-	-	1/Quarter	24hr Composite	Quarterly
01094 - Zinc, Total Recoverable - ug/l	-	-	-	-	-	-	1/Quarter	24hr Composite	Quarterly
01113 - Cadmium, Total Recoverable - ug/l	-	-	-	-	-	-	1/Quarter	24hr Composite	Quarterly
01114 - Lead, Total Recoverable - ug/l	-	-	-	-	-	-	1/Quarter	24hr Composite	Quarterly
01118 - Chromium, Total Recoverable - ug/l	-	-	-	-	-	-	1/Quarter	24hr Composite	Quarterly
01119 - Copper, Total Recoverable - ug/l	-	-	-	-	-	-	1/Quarter	24hr Composite	Quarterly
01220 - Chromium, Dissolved Hexavalent - ug/l	-	-	-	-	-	-	1/Quarter	Grab	Quarterly
50092 - Mercury, Total (Low Level) - ng/l	-	-	-	-	-	-	1/Quarter	Grab	Quarterly
61941 - pH, Maximum - S.U.	-	-	-	-	-	-	1/Day	Multiple Grab	All
61942 - pH, Minimum - S.U.	-	-	-	-	-	-	1/Day	Multiple Grab	All
80082 - CBOD 5 day - mg/l	-	-	-	-	-	-	3/Week	24hr Composite	All

NOTES for Station Number 2PD00000601:

- a. Cadmium, chromium, copper, lead, nickel, total filterable residue, and zinc shall be sampled on the same day as 2PD000000001.
- b. Dissolved hexavalent chromium shall be sampled one detention time prior to 2PD000000001.
- c. Mercury shall be sampled one detention time prior to 2PD000000001 - See Part II, Item X.1.c.

Part I, B. - UPSTREAM MONITORING REQUIREMENTS

9. Upstream Monitoring. During the period beginning on the effective date of this permit and lasting until the expiration date, the permittee shall monitor the receiving stream, upstream of the point of discharge at Station Number 2PD00000801, and report to the Ohio EPA in accordance with the following table. See Part II, OTHER REQUIREMENTS, for location of sampling.

Table - Upstream Monitoring - 801 - Final

Effluent Characteristic Parameter	Discharge Limitations				Monitoring Requirements			
	Concentration Specified Units		Loading* kg/day		Measuring Frequency	Sampling Type	Monitoring Months	
	Maximum	Minimum	Weekly	Monthly				
00010 - Water Temperature - C	-	-	-	-	1/Month	Grab	All	
00300 - Dissolved Oxygen - mg/l	-	-	-	-	1/Month	Grab	All	
00400 - pH - S.U.	-	-	-	-	1/Month	Grab	All	
00610 - Nitrogen, Ammonia (NH3) - mg/l	-	-	-	-	1/Month	Grab	All	
00625 - Nitrogen Kjeldahl, Total - mg/l	-	-	-	-	1/Month	Grab	All	
00630 - Nitrite Plus Nitrate, Total - mg/l	-	-	-	-	1/Month	Grab	All	
00665 - Phosphorus, Total (P) - mg/l	-	-	-	-	1/Month	Grab	All	
31648 - E. coli - #/100 ml	-	-	-	-	1 / 2 Weeks	Grab	June - Aug	
61432 - 48-Hr. Acute Toxicity Ceriodaphnia dubia - % Affected	-	-	-	-	2/Year	Grab	May and July	
61435 - 96-Hr. Acute Toxicity Pimephales promela - % Affected	-	-	-	-	1/Year	Grab	July	
61438 - 7-Day Chronic Toxicity Ceriodaphnia dubia - % Affected	-	-	-	-	2/Year	Grab	May and July	
61441 - 7-Day Chronic Toxicity Pimephales promelas - % Affected	-	-	-	-	1/Year	Grab	July	

NOTES for Station Number 2PD00000801:

- Water temperature, dissolved oxygen, pH, ammonia, and E. coli shall be sampled on the same day as 2PD00000001.
- Biomonitoring - See Part II, Item AA.
- If river conditions are unsafe for diluent collection, the permittee is authorized

Part I, B. - DOWNSTREAM-NEARFIELD MONITORING REQUIREMENTS

10. Downstream-Nearfield Monitoring. During the period beginning on the effective date of this permit and lasting until the expiration date, the permittee shall monitor the receiving stream, downstream of the point of discharge, at Station Number 2PD00000901, and report to the Ohio EPA in accordance with the following table. See Part II, OTHER REQUIREMENTS, for location of sampling.

Table - Downstream-Nearfield Monitoring - 901 - Final

Effluent Characteristic Parameter	Discharge Limitations			Monitoring Requirements		
	Concentration Maximum Minimum	Specified Units Weekly Monthly	Loading* Daily Weekly Monthly	Measuring Frequency	Sampling Type	Monitoring Months
00010 - Water Temperature - C	-	-	-	1/Month	Grab	All
00300 - Dissolved Oxygen - mg/l	-	-	-	1/Month	Grab	All
00400 - pH - S.U.	-	-	-	1/Month	Grab	All
00610 - Nitrogen, Ammonia (NH3) - mg/l	-	-	-	1/Month	Grab	All
00625 - Nitrogen Kjeldahl, Total - mg/l	-	-	-	1/Month	Grab	All
00630 - Nitrite Plus Nitrate, Total - mg/l	-	-	-	1/Month	Grab	All
00665 - Phosphorus, Total (P) - mg/l	-	-	-	1/Month	Grab	All
00900 - Hardness, Total (CaCO3) - mg/l	-	-	-	1/Month	Grab	All
31648 - E. coli - #/100 ml	-	-	-	1 / 2 Weeks	Grab	June - Aug

NOTES for Station Number 2PD00000901:

- a. Water temperature, dissolved oxygen, pH, ammonia, and E. coli shall be sampled on the same day as 2PD000000001.



## Part I, C - Schedule of Compliance

### A. WET Limits and Toxicity Reduction Evaluation (TRE)

As soon as possible but not later than the dates included in the following schedule, the permittee shall achieve compliance with the acute whole effluent toxicity (WET) limits at outfall 2PD00000001.

a. Not later than 6 months from the effective date of this permit, the permittee shall submit to Ohio EPA a copy of an initial investigation Toxicity Reduction Evaluation (TRE) work plan (1 - 2 pages). This plan shall describe the steps the permittee intends to follow if toxicity levels are greater than 2.21 TUc for *C. dubia* at outfall 2PD00000001 and should include at least the following items: (Event code 02199)

i. A description of the investigation and evaluation techniques that the permittee will use to identify potential causes and sources of toxicity and effluent variability.

ii. A description of the facility's procedures for conducting an in-plant survey to identify potential causes of the toxicity.

iii. An indication of the person or contractor who will conduct the TRE.

b. If the conditions of Part II, Item AA.5. are met and Ohio EPA notifies the permittee that it must conduct a TRE, the permittee shall use the Toxicity Reduction Evaluation Guidance for Municipal Wastewater Treatment Plants (EPA/833B-99/002; USEPA; August 1999) to develop a more detailed TRE work plan for achieving a maximum daily limit of 2.21 TUc for *C. dubia* at outfall 2PD00000001. This work plan will address the permittee's general approach for the TRE including:

i. Further actions to investigate and identify the cause of toxicity.

ii. Actions the permittee will take to prevent the recurrence of toxicity.

iii. A schedule for implementing these actions.

The permittee should consider the persistence and magnitude of the toxicity and determine whether a toxicity identification evaluation (TIE) would help identify the cause and source of toxicity. The permittee shall use Toxicity Identification Evaluation: Characterization of Chronically Toxic Effluents Phase 1 (EPA/600/6-91/005F; USEPA; May 1992) as guidance.

The two U.S. EPA guidance documents are available at the following Ohio EPA web site: [http://epa.ohio.gov/dsw/permits/technical\\_assistance.aspx](http://epa.ohio.gov/dsw/permits/technical_assistance.aspx).

Additional guidance is available in Clarifications Regarding Toxicity Reduction and Identification Evaluations in the National Pollutant Discharge Elimination System Program (USEPA; March, 27, 2001), which is linked on the above website, or available at:  
<https://epa.ohio.gov/portals/35/permits/usepa%20wet%20tre%20clarification%203%2001>

- c. Not later than 9 months after being notified by Ohio EPA that it must conduct a TRE, the permittee shall submit the detailed TRE work plan.
- d. Not later than 12 months after being notified by Ohio EPA that it must conduct a TRE, the permittee shall begin implementing the TRE work plan.
- e. Not later than 54 months after the effective date of this permit, the permittee shall achieve compliance with a daily maximum toxicity limit of 2.21 TUc for *C. dubia* at outfall 2PD00000001 (Event Code 05699)
- f. Reports required by this Schedule of Compliance for whole effluent toxicity must be submitted to Ohio EPA, Division of Surface Water, NPDES Permit Unit, P.O. Box 1049, Columbus, OH, 43216-1049. A copy shall also be sent to the Ohio EPA Northwest District Office.

#### B. Wet Weather Improvement Plan

The permittee submitted a Wet Weather Improvement Plan (WWIP) on June 20, 2018 to serve as an update to the permittee's Long Term Control Plan. The WWIP was amended on March 20, 2019 and approved by Ohio EPA on May 27, 2019. The WWIP proposes to attain a level of control of five CSO events or fewer per typical year and elimination of the remaining SSO outfalls in the collection system. The permittee shall implement the WWIP as expeditiously as possible, but not later than the dates developed in accordance with the following schedule.

##### 1. WWIP Implementation Schedule

###### a. Williams Pump Station Replacement

- i. Not later than December 31, 2021, the permittee shall complete construction of the Williams Pump Station Replacement project. Notify the Ohio EPA Northwest District Office within seven days of completing this item. (Event code 05599)

b. Haley SSO Elimination

i. Not later than December 31, 2021, the permittee shall begin design on the Haley SSO Elimination project. (Event code 00999)

ii. Not later than December 31, 2022, the permittee shall complete construction of the Haley SSO Elimination project. Notify the Ohio EPA Northwest District Office within seven days of completing this item. (Event code 91099)

c. Van Hying Pump Station Replacement

i. Not later than December 31, 2020, the permittee shall begin design of the Van Hying Pump Station Replacement project. (Event code 00999)

ii. Not later than December 31, 2023, the permittee shall complete construction of the Van Hying Pump Station Replacement project. Notify the Ohio EPA Northwest District Office within seven days of completing this item. (Event code 05599)

d. Glenwood SSO Relief

i. Not later than December 31, 2020, the permittee shall begin design of the Glenwood SSO Relief project. (Event code 00999)

ii. Not later than December 31, 2023, the permittee shall complete construction of the Glenwood SSO Relief project. Notify the Ohio EPA Northwest District Office within seven days of completing this item. (Event code 05599)

e. Glenwood SSO Elimination

i. The permittee shall conduct post-construction monitoring of the Glenwood SSO for at least 12 months prior to elimination of the outfall.

i. Not later than December 31, 2024, the permittee shall begin design of the Glenwood SSO Elimination.

iii. Not later than December 31, 2025, the permittee shall complete construction of the Glenwood SSO Elimination project. Notify the Ohio EPA Northwest District Office within seven days of completing this item.

f. East Washington Interceptor Improvements

i. Not later than December 31, 2025, the permittee shall begin design of the East Washington Interceptor Improvements.

ii. Not later than December 31, 2029, the permittee shall complete construction of the East Washington Interceptor Improvements. Notify the Ohio EPA Northwest District Office within seven days of completing this item.

g. WWTP Improvements, Phase 1

- i. Not later than December 31, 2025, the permittee shall begin design of the WWTP Improvements, Phase 1.
- ii. Not later than December 31, 2029, the permittee shall complete construction of the WWTP Improvements, Phase 1. Notify the Ohio EPA Northwest District Office within seven days of completing this item.

2. WWIP Programmatic Review

Prior to the expiration date of this permit, the permittee shall evaluate progress toward attaining the goals of the WWIP. The permittee shall implement a flow monitoring program of at least 12 months which will assess the success of the previously completed projects, evaluate the appropriateness of future projects, and justify any proposed changes to the established compliance schedule. A final report detailing the findings of this review must be submitted no later than July 31, 2023. (Event Code 61099)

3. Post-Construction Compliance Monitoring

Upon completion of the WWIP projects, the permittee shall implement a post-construction compliance monitoring program to assess the effectiveness of the CSO controls.

4. Annual Reporting

The permittee shall submit annual progress reports on implementation of wet weather improvement projects to Ohio EPA Northwest District Office for activities performed during the previous calendar year.

- a. Annual reports shall, at a minimum, include the following:
  - i. The design or construction status of WWIP projects listed in Item B.1 above;
  - ii. A brief description of I/I removal projects completed during the previous year and projected to begin in the upcoming year;
  - iii. Identified illicit detections including dates identified and eliminated. If the illicit connection has not been eliminated, provide a reason and timeline for elimination; and
  - iv. Post-construction monitoring results and discussion regarding progress toward the goals of the WWIP.
- b. The annual progress report shall be submitted on or before the following dates:
  - i. June 30, 2020 (Event code 03599)
  - ii. June 30, 2021 (Event code 03699)
  - iii. June 30, 2022 (Event code 03799)

iv. June 30, 2023 (Event code 03899)

v. June 30, 2024 (Event code 03999)

C. This Schedule of Compliance includes items that extend beyond the expiration date of this permit, 2PD00000\*SD. The requirements of Schedule of Compliance will be included in permit 2PD00000 when it is renewed.

## Part II, Other Requirements

### A. Operator Certification Requirements

#### 1. Classification

a. In accordance with Ohio Administrative Code 3745-7-04, the sewage treatment facility at this facility shall be classified as a Class III facility. The permittee shall designate one or more professional operator of record to oversee the technical operation of the treatment works with a valid certification of a class equal to or greater than the classification of the treatment works.

b. All sewerage (collection) systems that are tributary to this treatment works are Class II sewerage systems in accordance with paragraph (B)(1)(b) of rule 3745-7-04 of the Ohio Administrative Code. The permittee shall designate one or more professional operator of record to oversee the technical operation of the sewerage (collection) system with a valid certification of a class equal to or greater than the classification of the sewerage (collection) system.

#### 2. Professional Operator of Record

a. Within three days of a change in a professional operator of record, the permittee shall notify the Director of the Ohio EPA of any such change on a form acceptable to Ohio EPA. The appropriate form can be found at the following website:

<http://epa.ohio.gov/Portals/28/documents/opcert/Operator%20of%20Record%20Notification%20Form.pdf>

b. All applications for renewal of this NPDES permit shall include an updated Operator of Record Notification form along with other necessary forms and fees to be considered a complete application.

c. The professional operator of record for a class II, III, or IV treatment works or class II sewerage system may be replaced by a backup professional operator with a certificate one classification lower than the treatment works or sewerage system for a period of up to thirty consecutive days. The use of this provision does not require notification to the agency. This provision may not be used to routinely circumvent minimum staffing requirements.

d. Upon proper justification, such as military leave or long term illness, the director may authorize the replacement of the professional operator of record for a class II, III, or IV treatment works or class II sewerage system by a backup professional operator with a certificate one classification lower than the facility for a period of greater than thirty consecutive days. Such requests shall be made in writing to the appropriate district office.

### 3. Minimum Staffing Requirements

a. The permittee shall ensure that the treatment works professional operator of record is physically present at the facility in accordance with the minimum staffing requirements per paragraph (C)(1) of rule 3745-7-04 of the Ohio Administrative Code or the requirements from an approved 3745-7-04(C) minimum staffing hour reduction plan.

b. The permittee shall ensure that the collection system professional operator of record or a professional operator that is certified in the field of wastewater collection or wastewater treatment, class A operators excluded, is physically present at the collection system in accordance with the minimum staffing requirements per paragraph (C)(2) of rule 3745-7-04 of the Ohio Administrative Code.

c. If Ohio EPA approves a reduction in minimum staffing requirements based upon a facility operating plan, any change in the criteria under which the operating plan was approved (e.g., retirement of a professional operator listed in the approved staffing plan, loss of the professional operator of record, reduction in the workforce, removal or failure of automation or continuous monitoring, etc.) will require

that the treatment works immediately return to the minimum staffing requirements included in paragraph (C)(1) of rule 3745-7-04 of the Ohio Administrative Code.

### 4. Additional Staffing Requirements

Visits to all treatment works shall be performed by the permittee, the permittee's representative, or agent five days a week and noted in the operational and maintenance records required by rule 3745-7-09 of the Administrative Code. Visits shall not be necessary when the treatment works is not in operation.

B. Description of the location of the required sampling stations are as follows:

Sampling Station	Description of Location
2PD00000001	Final effluent after disinfection; combined with EQ overflow during wet weather (Lat: 41 N 23' 37"; Long: 84 W 06' 49")
2PD00000003	Combined Sewer Overflow - see part II, Item C
2PD00000004	Combined Sewer Overflow - see part II, Item C
2PD00000006	Combined Sewer Overflow - see part II, Item C
2PD00000010	Combined Sewer Overflow - see part II, Item C
2PD00000011	Combined Sewer Overflow - see part II, Item C
2PD00000300	System-wide Sanitary Sewer Overflow (SSO) occurrences
2PD00000302	SSO occurrences at Hayley and Riverview (Lat: 41 N 23' 3.6"; Long: 84 W 07' 53.2")
2PD00000303	SSO occurrences at Glenwood and Riverview (Lat: 41 N 22' 54.5"; Long: 84 W 08' 27.1")
2PD00000581	Sludge removed for land application
2PD00000586	Sludge removed to landfill
2PD00000588	Sludge removed to another NPDES permit holder
2PD00000601	Influent monitoring
2PD00000603	EQ basin overflow prior to disinfection
2PD00000801	Upstream monitoring
2PD00000901	Downstream monitoring

C. The permittee is authorized to discharge from the following combined sewer overflows (CSOs) only during wet weather periods when the flow in the sewer system exceeds the capacity of the sewer system. See Part I,B for applicable monitoring and reporting requirements. Also see Part III, Item 11.

CSO Station	Description of Location	Receiving Stream
2PD00000003	Central CSO; Scott St. and W. Riverview Ave	Maumee River
2PD00000004	Monroe CSO; Monroe St. and E. Riverview Ave	Maumee River
2PD00000006	Oakwood CSO; Oakwood Ave. and Yeager St.	Oberhaus Creek
2PD00000010	Dodd CSO; Dodd St. and Yeager St.	Oberhaus Creek
2PD00000011	WWTP 011 CSO; east of WWTP influent station	Maumee River

The following public access areas are potentially impacted by CSO discharges:

Area Name	Description of Location	Associated
Boat ramp	Near Glenwood Ave and W. Riverview Ave	303



#### D. Public Notification Requirements for CSO discharges to the Lake Erie Basin

Each permittee with authorized CSO discharges to the Lake Erie Basin must provide public notification of such discharges in accordance with 40 CFR 122.38(a). At a minimum, such notification shall consist of the following:

##### 1. Signage

The permittee shall ensure that adequate signage, where feasible, is posted at all CSO outfall locations and potentially impacted public access areas, as identified in Part II, Item, C. The signage shall adhere to the Outfall Signage requirements of Part II, Item F.

##### 2. Notification of Local Public Health Department(s) and Other Potentially Affected Public Entities

###### a. Initial Notification

As soon as possible, but no later than four (4) hours after becoming aware of a CSO discharge, the permittee shall notify the appropriate local Department of Health and other affected public entities, as identified in the Public Notification Plan. Such initial notice shall, at a minimum, include the following information:

- i. The name of the affected water body;
- ii. The location of the discharge and potentially impacted public access areas;
- iii. The date and time that the discharge began;
- iv. The approximate time that the discharge ended or if the discharge is ongoing, and;
- v. A point of contact for the permittee.

###### b. Supplemental Notification

The permittee shall notify the appropriate local Department of Health and other affected public entities, as identified in the Public Notification Plan, within seven (7) days of becoming aware of a CSO discharge, unless the information has been provided in an earlier notice. Notification shall include:

- i. The volume of the discharge and;
- ii. The approximate time that the discharge ended.

### 3. Notification of the Public

#### a. Initial Notification

As soon as possible, but no later than four (4) hours after becoming aware of a CSO discharge, the permittee shall provide initial notification to the public, as identified in the Public Notification Plan. Such initial notice shall include, at a minimum, the following information:

- i. The name of the affected water body;
- ii. The location of the discharge and potentially impacted public access areas;
- iii. The date and time that the discharge began, and;
- iv. The approximate time that the discharge ended or if the discharge is ongoing.

#### b. Supplemental Notification

The permittee shall provide supplemental notification to the public, as identified in the Public Notification Plan, within seven (7) days of becoming aware of a CSO discharge, unless the information has been provided in an earlier notice. The notification shall include:

- i. The volume of the discharge and;
- ii. The approximate time that the discharge ended.

#### 4. Annual Report

On or prior to May 1st of each year, the permittee shall make available to the public an Annual Report describing the CSO discharges from its discharge point(s) that occurred in the previous calendar year, in accordance with 40 CFR 122.38(b). Upon public availability of the Annual Report, the permittee shall submit instructions on how to access the Annual Report to Ohio EPA Northwest District Office and U.S. EPA. Such notice to US EPA shall be in the form of an email to NPDES\_CSO@epa.gov.

At a minimum, the Annual Report shall include:

- a. A description of the location and receiving water for each CSO discharge point, and, if applicable, any treatment provided;
- b. The date, location, approximate duration, measured or estimated volume, and cause (e.g., rainfall, snowmelt) of each wet weather CSO discharge that occurred during the past calendar year;
- c. The date, location, duration, volume, and cause of each dry weather CSO discharge that occurred during the past calendar year;
- d. A summary of available monitoring data for CSO discharges from the past calendar year;
- e. A description of any public access areas potentially impacted by each CSO discharge;
- f. Representative precipitation data in total inches to the nearest 0.1 inch that resulted in a CSO discharge, if precipitation was the cause of the discharge;
- g. Permittee contact information; and
- h. A concise summary of implementation of the nine minimum controls and the status of implementation of the CSO long-term control plan (or other plans to reduce or prevent CSO discharges), including:
  - (i) A description of key milestones remaining to complete implementation of the plan; and
  - (ii) A description of the average annual number of CSO discharges anticipated after implementation of the long-term control plan (or other plan relevant to reduction of CSO overflows) is completed.

#### E. Nine Minimum Controls

The entire wastewater treatment system shall be operated and maintained so that the total loading of pollutants discharged during wet weather is minimized. To accomplish this, the permittee shall utilize the following technologies:

- 1) provide proper operation and maintenance for the collection system and the combined sewer overflow points;
- 2) provide the maximum use of the collection system for storage of wet weather flow prior to allowing overflows;
- 3) review and modify the pretreatment program to minimize the impact of non-domestic discharges from combined sewer overflows; or if there is no pretreatment program review and modify local programs to minimize the impact of non-domestic discharges from combined sewer overflows;
- 4) maximize the capabilities of the POTW to treat wet weather flows, and maximize the wet weather flow to the wastewater treatment plant within the limits of the plant's capabilities;
- 5) prohibit dry weather overflows;
- 6) control solid and floatable materials in the combined sewer overflow discharge;
- 7) conduct required inspection, monitoring and reporting of CSOs;
- 8) implement pollution prevention programs that focus on reducing the level of contaminants in CSOs; and
- 9) implement a public notification program for areas affected by CSOs, especially beaches and recreation areas.

#### F. Outfall Signage

The permittee shall maintain a permanent sign on the stream bank at each outfall that is regulated under this NPDES permit. This includes final outfalls, bypasses, and combined sewer overflows. The sign shall include, at a minimum, the name of the establishment to which the permit was issued, the Ohio EPA permit number, and the outfall number and a contact telephone number. The information shall be printed in letters not less than two inches in height. The sign shall be a minimum of 2 feet by 2 feet and shall be a minimum of 3 feet above ground level. The sign shall not be obstructed such that persons in boats or persons swimming on the river or someone fishing or walking along the shore cannot read the sign. Vegetation shall be periodically removed to keep the sign visible. If the outfall is normally submerged the sign shall indicate that. If the outfall is a combined sewer outfall, the sign shall indicate that untreated human sewage may be discharged from the outfall during wet weather and that harmful bacteria may be present in the water. When an existing sign is replaced or reset, the new sign shall comply with the requirements of this section.

G. All parameters, except flow, need not be monitored on days when the plant is not normally staffed (Saturdays, Sundays, and Holidays). On those days, report "AN" on the monthly report form.

## H. Sanitary Sewer Overflow Reporting

A sanitary sewer overflow is an overflow, spill, release, or diversion of wastewater from a sanitary sewer system. SSOs do not include wet weather discharges from combined sewer overflows specifically listed in Part II of this NPDES permit (if any). All SSOs are prohibited.

### 1. Reporting for SSOs That Imminently and Substantially Endanger Human Health

#### a) Immediate Notification

You must notify Ohio EPA (1-800-282-9378) and the appropriate Board of Health (i.e., city or county) within 24 hours of learning of any SSO from your sewers or from your maintenance contract areas that may imminently and substantially endanger human health. The telephone report must identify the location, estimated volume and receiving water, if any, of the overflow. An SSO that may imminently and substantially endanger human health includes dry weather overflows, major line breaks, overflow events that result in fish kills or other significant harm, overflows that expose the general public to contact with raw sewage, and overflow events that occur in sensitive waters and high exposure areas such as protection areas for public drinking water intakes and waters where primary contact recreation occurs.

#### b) Follow-Up Written Report

Within 5 days of the time you become aware of any SSO that may imminently and substantially endanger human health, you must provide the appropriate Ohio EPA district office a written report that includes:

- (i) the estimated date and time when the overflow began and stopped or will be stopped (if known);
- (ii) the location of the SSO including an identification number or designation if one exists;
- (iii) the receiving water (if there is one);
- (iv) an estimate of the volume of the SSO (if known);
- (v) a description of the sewer system component from which the release occurred (e.g., manhole, constructed overflow pipe, crack in pipe);
- (vi) the cause or suspected cause of the overflow;
- (vii) steps taken or planned to reduce, eliminate, and prevent reoccurrence of the overflow and a schedule of major milestones for those steps; and
- (viii) steps taken or planned to mitigate the impact(s) of the overflow and a schedule of major milestones for those steps.

An acceptable 5-day follow-up written report can be filled-in or downloaded from the Ohio EPA Division of Surface Water Permits Program Technical Assistance Web page at:

[http://www.epa.ohio.gov/dsw/permits/technical\\_assistance.aspx](http://www.epa.ohio.gov/dsw/permits/technical_assistance.aspx).

## 2. Reporting for All SSOs, Including Those That Imminently and Substantially Endanger Human Health

a) Discharge Monitoring Reports (DMR) Sanitary sewer overflows that enter waters of the state, either directly or through a storm sewer or other conveyance, shall be reported on your Discharge Monitoring Reports (DMR). You must report the system-wide number of occurrences for SSOs that enter waters of the state in accordance with the requirements for station number 300. A monitoring table for this station is included in Part I, B of this NPDES permit. For the purpose of counting occurrences, each location on the sanitary sewer system where there is an overflow, spill, release, or diversion of wastewater on a given day is counted as one occurrence. For example, if on a given day overflows occur from a manhole at one location and from a damaged pipe at another location and they both enter waters of the state, you should record two occurrences for that day. If overflows from both locations continue on the following day, you should record two occurrences for the following day. At the end of the month, total the daily occurrences from all locations on your system and report this number using reporting code 74062 (Overflow Occurrence, No./Month) on the 4500 form for station number 300.

### b) Annual Report

You must prepare an annual report of all SSOs in your collection system, including those that do not enter waters of the state. The annual report must be in an acceptable format (see below) and must include:

- (i) A table that lists an identification number, a location description, and the receiving water (if any) for each existing SSO. If an SSO previously included in the list has been eliminated, this shall be noted. Assign each SSO location a unique identification by numbering them consecutively, beginning with 301.
- (ii) A table that lists the date that an overflow occurred, the unique ID of the overflow, the name of affected receiving waters (if any), and the estimated volume of the overflow (in millions of gallons). The annual report may summarize information regarding overflows of less than approximately 1,000 gallons.
- (iii) A table that summarizes the occurrence of water in basements (WIBs) by total number and by sewershed. The report shall include a narrative analysis of WIB patterns by location, frequency and cause. Only WIBs caused by a problem in the publicly-owned collection system must be included.

Not later than March 31 of each year, you must submit one copy of the annual report for the previous calendar year. The report may be submitted electronically using the NPDES Annual Sanitary Sewer Overflow Report available through the Ohio EPA eBusiness Center, Division of Surface Water NPDES Permit Applications service. Alternatively, you may submit one hardcopy of the report to the appropriate Ohio EPA district office and one copy to: Ohio EPA; Division of Surface Water; NPDES Permit Unit; P.O. Box 1049; Columbus, OH, 43216-1049. An acceptable annual SSO report can be filled-in or downloaded from the Ohio EPA Division of Surface Water Permits Program Technical Assistance Web page at: [http://www.epa.ohio.gov/dsw/permits/technical\\_assistance.aspx](http://www.epa.ohio.gov/dsw/permits/technical_assistance.aspx).

You also must provide adequate notice to the public of the availability of the report. Adequate public notice would include: notices posted at the community administration building, the public library and the post office; a public notice in the newspaper; or a notice sent out with all sewer bills.

I. The permittee shall maintain in good working order and operate as efficiently as possible the "treatment works" and "sewerage system" as defined in ORC 6111.01 to achieve compliance with the terms and conditions of this permit and to prevent discharges to the waters of the state, surface of the ground, basements, homes, buildings, etc.

J. Composite samples shall be comprised of a series of grab samples collected over a 24-hour period and proportionate in volume to the sewage flow rate at the time of sampling. Such samples shall be collected at such times and locations, and in such a fashion, as to be representative of the facility's overall performance.

K. Grab samples shall be collected at such times and locations, and in such fashion, as to be representative of the facility's performance.

L. Multiple grab samples shall be comprised of at least three grab samples collected at intervals of at least three hours during the period that the plant is staffed on each day for sampling. Samples shall be collected at such times and locations, and in such fashion, as to be representative of the facility's overall performance. The critical value shall be reported.

M. The treatment works must obtain at least 85 percent removal of carbonaceous biochemical oxygen demand (five-day) and suspended solids (see Part III, Item 1).

N. Water quality based permit limitations in this permit may be revised based on updated wasteload allocations or use designation rules. This permit may be modified, or revoked and reissued, to include new water quality based effluent limits or other conditions that are necessary to comply with a revised wasteload allocation, or an approved total maximum daily loads (TMDL) report as required under Section 303 (d) of the Clean Water Act.

O. Reserved

P. Reserved

Q. Reserved

R. All disposal, use, storage, or treatment of sewage sludge by the Permittee shall comply with Chapter 6111. of the Ohio Revised Code, Chapter 3745-40 of the Ohio Administrative Code and any further requirements specified in this NPDES permit, and any other actions of the Director that pertain to the disposal, use, storage, or treatment of sewage sludge by the Permittee.

S. Sewage sludge composite samples shall consist of a minimum of six grab samples collected at such times and locations, and in such fashion, as to be representative of the facility's sewage sludge.

T. No later than March 1 of each calendar year, the Permittee shall submit a report summarizing the sewage sludge disposal, use, storage, or treatment activities of the Permittee during the previous calendar year. The report shall be submitted through the Ohio EPA eBusiness Center, Division of Surface Water NPDES Permit Applications service.

U. Each day when sewage sludge is removed from the wastewater treatment plant for use or disposal, a representative sample of sewage sludge shall be collected and analyzed for percent total solids. This value of percent total solids shall be used to calculate the total Sewage Sludge Weight (Discharge Monitoring Report code 70316) and/or total Sewage Sludge Fee Weight (Discharge Monitoring Report code 51129) removed from the treatment plant on that day. The results of the daily monitoring and the weight calculations shall be maintained on site for a minimum of five years. The test methodology used shall be from Part 2540 G of Standard Methods for the Examination of Water and Wastewater American Public Health Association, American Water Works Association, and Water Environment Federation, using the edition which is current on the issuance date of the permit. To convert from gallons of liquid sewage sludge to dry tons of sewage sludge:  $\text{dry tons} = \text{gallons} \times 8.34 \text{ (lbs/gallon)} \times 0.0005 \text{ (tons/lb)} \times \text{decimal fraction total solids}$ .



#### V. Notification to Public Water Supply Operators.

1. As required by the Ohio Administrative Code 3745-33-08(F), permits for facilities designated by the director as major discharges, in the following locations, shall require the permittee to notify the public water supply operator as soon as practicable after a discharge begins that results from a spill, separate sewer overflow, bypass, upset, or combined sewer overflow that reaches waters of the state:

- a. Discharges within three thousand feet of a public water supply intake located in a lake; or
- b. Discharges within ten stream miles upstream of a public water supply intake located in a reservoir or any other surface water of the state.

2. Public water supply operators meeting the criteria in Part II, Item V.1 above for the Napoleon WWTP are:

Campbell Soup Supply Company, 12-773 State Route 110, Napoleon, Ohio 43545  
Aaron McCoy, 419-599-6865

City of Napoleon Water Treatment Plant, 527 Welsted Street Napoleon, Ohio 43545  
Jeff Weis, 419-592-8811

3. The permittee shall continue to implement notification procedures between the wastewater system operator and public water supply operators listed above in Part II, Item V.2 that defines the specific notification requirements to the public water supply operator and what constitutes notification "as soon as practicable".

#### W. Monitoring for Dissolved Orthophosphate (as P)

The permittee shall monitor for dissolved orthophosphate by grab sample. The permittee shall filter the grab sample within 15 minutes of collection using a 0.45-micron filter. The filtered sample must be analyzed within 48 hours. Samples shall be collected at such times and locations, and in such fashion, as to be representative of the facility's overall performance.

#### X. General Mercury Variance

The permittee is granted a renewal of the general mercury variance under the provisions of Rule 3745-01-38(H) of the Ohio Administrative Code. The City of Napoleon has demonstrated that the facility is currently unable to comply with the monthly average water quality based effluent limit of 1.3 ng/l without construction of expensive end-of-pipe controls more stringent than those required by sections 301(b) and 306 of the Clean Water Act. The City of Napoleon is currently able to achieve an annual average mercury concentration of 12 ng/l. For general mercury variance purposes, the annual average mercury effluent concentration is defined as the average of the most recent 12 months of effluent data.

One of the conditions of the general mercury variance is that the permittee make reasonable progress towards attaining the water quality based effluent limits for mercury (1.b, below). To accomplish this, the permittee is required to continue implementing a pollutant minimization program (PMP) for mercury. The elements of a PMP include: a control strategy to locate, identify and, where cost-effective, reduce levels of mercury that contribute to discharge levels; periodic monitoring of sources and the treatment system; and annual reporting of results.

The plan of study that was part of the permittee's 2009 application for coverage under the general mercury variance included items associated with developing a control strategy and initial implementation of a PMP. By implementing the plan of study and meeting other conditions of its NPDES permit, the permittee has been taking actions consistent with a PMP for mercury. Condition 1.d below, requires the permittee to continue implementing a PMP for mercury.

1. As conditions of this variance, the permittee shall meet the following requirements:

a. The permittee shall comply with the effluent limitations for mercury at outfall 2PD00000001 given in Part I, A. of this permit.

b. The permittee shall make reasonable progress towards attaining the monthly average water quality-based effluent limit for mercury by complying with the general mercury variance conditions included in this NPDES permit.

c. The permittee shall use EPA Method 1631 to comply with the influent and effluent mercury monitoring requirements of this permit.

d. The permittee shall continue implementing a PMP for mercury consistent with the plan of study included in the permittee's mercury variance application submitted on December 21, 2018 and any other relevant information submitted by the permittee, including the following activities:

- i. Collect samples in sewer system to identify contributing sources;
- ii. Conduct site visits at identified sources to distribute guidance for and encourage implementation of reduction strategies;
- iii. Contact local waste management district regarding strategies and events for collection of mercury-containing wastes;
- iv. Implement a sewer cleaning and rehabilitation program in coordination with the City's LTCP.

e. The permittee shall assess the impact of the mercury variance on public health, safety, and welfare by, as a minimum, monitoring for mercury in the facility's influent and effluent as required by this NPDES permit.

f. The permittee shall maintain an annual average mercury effluent concentration equal to or less than 12 ng/l.

g. On or prior to March 1 of each year, the permittee shall submit two copies of an annual PMP report to Ohio EPA, Division of Surface Water, NPDES Permit Unit, P.O. Box 1049, Columbus, OH, 43216-1049. The annual PMP report shall include:

- i. All minimization program monitoring results for the year
- ii. A list of potential sources of mercury
- iii. A summary of all actions taken to meet the effluent limits for mercury
- iv. Any updates of the control strategy, including actions planned to reduce the levels of mercury in the treatment plant's final effluent

The Ohio EPA Annual Mercury PMP Report and Appendices are available on the Division of Surface Water Permits Program Technical Assistance web page at: [http://www.epa.ohio.gov/dsw/permits/technical\\_assistance.aspx](http://www.epa.ohio.gov/dsw/permits/technical_assistance.aspx) . Open the Mercury list.

h. Upon completion of the actions identified in the plan of study as required in Part II, Item X.1.d. of this permit or upon submittal of the permittee's NPDES permit renewal application, whichever comes first, the permittee shall submit to Ohio EPA's Northwest District Office a certification stating that all permit conditions imposed to implement the plan of study and the PMP have been satisfied and whether compliance with the monthly average water quality based effluent limit for mercury has been achieved and can be maintained. This certification shall be accompanied by the following:

- i. All available mercury influent and effluent data for the most recent 12 month period.
- ii. Data documenting all known significant sources of mercury and the steps that have been taken to reduce or eliminate those sources; and
- iii. A determination of the lowest mercury concentration that currently available data indicate can be reliably achieved through implementation of the PMP.

2. Exceedance of the annual average limit of 12 ng/l. a. If at any time after the effective date of this permit, the permittee's annual average mercury effluent concentration exceeds 12 ng/l, the permittee shall:

- i. Notify Ohio EPA's Northwest District Office not later than 30 days from the date of the exceedance.
- ii. Submit an individual variance application, if a variance is desired, not later than 6 months from the date of the exceedance; or
- iii. Request a permit modification not later than 6 months from the date of the exceedance for a compliance schedule to attain compliance with the water quality-based effluent limits for mercury.

b. If the permittee complies with either 2.a.ii or 2.a.iii, above, the general mercury variance conditions included in this NPDES permit will remain in effect until the date that the Director acts on the individual variance application or the date that the permit modification becomes effective.

c. If the permittee does not comply with either 2.a.ii or 2.a.iii, above, a monthly water-quality based effluent limit for mercury of 1.3 ng/l shall apply at outfall 2PD00000001 beginning 6 months from the date of the exceedance.

3. The requirements of Part II, Item X.2 shall not apply if the permittee demonstrates to the satisfaction of the Director that the mercury concentration in the permittee's effluent exceeds 12 ng/l due primarily to the presence of mercury in the permittee's intake water.

#### Y. Permit Reopener for Mercury Variance Revisions

Ohio EPA may reopen and modify this permit at any time based upon Ohio EPA water quality standard revisions to the mercury variance granted in Part II, Item X of this permit.

#### Z. Renewal of Mercury Variance

For renewal of the mercury variance authorized in this permit, the permittee shall include the following information with the submittal of the subsequent NPDES permit renewal application:

1. the certification described under Part II, Item X.1.h., and all information required under Part II, Item X.1.h.i. through Part II, Item X.1.h.iii;
2. a status report on the progress being made implementing the pollutant minimization program (PMP). This information may be included in the annual PMP report required under Part II, Item X.1.g;
3. a listing of the strategies and/or programs in the PMP which will be continued under the next renewal of this permit; and
4. a statement requesting the renewal of the mercury variance.

## AA. Biomonitoring Program Requirements

The permittee shall continue to implement an effluent biomonitoring program to determine the toxicity of the effluent from outfall 2PD00000001.

### General Requirements

All toxicity testing conducted as required by this permit shall be done in accordance with "Reporting and Testing Guidance for Biomonitoring Required by the Ohio Environmental Protection Agency" (hereinafter, the "biomonitoring guidance"), Ohio EPA, July 1998 (or current revision). The Standard Operating Procedures (SOP) or verification of SOP submittal, as described in Section 1.B. of the biomonitoring guidance shall be submitted no later than three months after the effective date of this permit. If the laboratory performing the testing has modified its protocols, a new SOP is required.

### Testing Requirements

#### 1. Chronic Bioassays

For the life of the permit, the permittee shall conduct chronic toxicity tests semi-annually using *Ceriodaphnia dubia* and annually using fathead minnows (*Pimephales promelas*) on effluent samples from outfall 2PD00000001. These tests shall be conducted as specified in Section 3 of the biomonitoring guidance.

#### 2. Acute Bioassays

For the life of the permit, the permittee shall conduct definitive acute toxicity tests semi-annually using *Ceriodaphnia dubia* and annually using fathead minnows (*Pimephales promelas*) on effluent samples from outfall 2PD00000001. These tests shall be conducted as specified in Section 2 of the biomonitoring guidance. Acute toxicity tests need not be performed for months in which chronic toxicity tests are conducted. Acute endpoints, as described in Section 2.H. of the biomonitoring guidance, shall be derived from the chronic test.

#### 3. Testing of Ambient Water

In conjunction with the acute and chronic toxicity tests, upstream control water shall be collected at a point outside the zone of effluent and receiving water interaction at station 2PD00000801. Testing of ambient waters shall be done in accordance with Sections 2 and 3 of the biomonitoring guidance.

#### 4. Data Review

##### a. Reporting

Following completion of each semi-annual bioassay requirement, the permittee shall report results of the tests in accordance with Sections 2.H.1., 2.H.2.a., 3.H.1., and 3.H.2.a. of the biomonitoring guidance, including reporting the results on the monthly DMR and submitting a copy of the complete test report to Ohio EPA, Division of Surface Water. The test report may be submitted electronically using the acute or chronic NPDES Biomonitoring Report Form available through the Ohio EPA eBusiness Center, Division of Surface Water NPDES Permit Applications service. Alternatively, the permittee may submit a hard copy of the report to Ohio EPA, Division of Surface Water, NPDES Permit Unit, P.O. Box 1049, Columbus, OH, 43216-1049.

Based on Ohio EPA's evaluation of the results, this permit may be modified to require additional biomonitoring, require a toxicity reduction evaluation, and/or contain whole effluent toxicity limits.

##### b. Definitions

$TU_a = \text{Acute Toxicity Units} = 100/LC50$

$TU_c = \text{Chronic Toxicity Units} = 100/IC25$

This equation for chronic toxicity units applies outside the mixing zone for warmwater, modified warmwater, exceptional warmwater, coldwater, and seasonal salmonid use designations except when the following equation is more restrictive (*Ceriodaphnia dubia* only):

$TU_c = \text{Chronic Toxic Units} = 100/\text{square root of } (NOEC \times LOEC)$

#### 5. Trigger to initiate a toxicity reduction evaluation (TRE)

Based upon evaluation of the data required under 2.a., above, Ohio EPA personnel will determine if a TRE will be required of the permittee. A decision to require a TRE will be based upon professional judgment and the following decision criteria:

- a. Two or more tests exceed the maximum level of 2.21  $TU_c$  for *C. dubia* or *P. promelas* in the outfall 2PD00000001 effluent;
- b. A review of the test procedures for adequacy, and
- c. Evaluation of the normality of process and treatment plant operations at the time of sampling.

The permittee shall receive written notification from Ohio EPA if a TRE is required.

#### AB. Whole Effluent Toxicity Reopener

This permit may be modified to remove the limits for whole effluent toxicity at station 2PD00000001 and the schedule of compliance for toxicity limits. A request for such a modification shall be based on the results of at least eight definitive chronic toxicity tests conducted by the permittee over a period of four years. These tests shall be done in a manner consistent with the "General Requirements" and "Testing Requirements" included in Part II, Item AA of this NPDES permit. The results of these tests shall be evaluated using 40 CFR Part 132, Appendix F, Procedure 6 and OAC 3745-33-07(B)(10). To support a modification, the evaluation should show that there is no reasonable potential for the Napoleon WWTP discharge to cause or contribute to a violation of the criteria for whole effluent toxicity.

#### AC. CSO Reopener

This permit may be modified upon determination that CSO controls fail to meet the water quality goals of the CSO Policy. The permittee shall be notified of such a determination by Ohio EPA and shall be required to develop, submit, and implement a revised CSO control plan which contains additional controls.

#### AD. Phosphorus Optimization

The permittee shall continue to evaluate collected effluent data, possible source reduction measures, operational improvements, and minor facility modifications that will optimize reductions in phosphorus discharges from the WWTP.

#### AE. Dilution Water Substitution

The permittee is authorized to use a dilution water substitute for whole effluent toxicity testing if conditions are unsafe for collection of dilution water from the Maumee River. The permittee shall adhere to the dilution water substitute options and reporting requirements outlined in the biomonitoring guidance.

## PART III - GENERAL CONDITIONS

### 1. DEFINITIONS

"Daily discharge" means the discharge of a pollutant measured during a calendar day or any 24-hour period that reasonably represents the calendar day for purposes of sampling. For pollutants with limitations expressed in units of mass, the "daily discharge" is calculated as the total mass of the pollutant discharged over the day. For pollutants with limitations expressed in other units of measurement, the "daily discharge" is calculated as the average measurement of the pollutant over the day.

"Average weekly" discharge limitation means the highest allowable average of "daily discharges" over a calendar week, calculated as the sum of all "daily discharges" measured during a calendar week divided by the number of "daily discharges" measured during that week. Each of the following 7-day periods is defined as a calendar week: Week 1 is Days 1 - 7 of the month; Week 2 is Days 8 - 14; Week 3 is Days 15 - 21; and Week 4 is Days 22 - 28. If the "daily discharge" on days 29, 30 or 31 exceeds the "average weekly" discharge limitation, Ohio EPA may elect to evaluate the last 7 days of the month as Week 4 instead of Days 22 - 28. Compliance with fecal coliform bacteria or E coli bacteria limitations shall be determined using the geometric mean.

"Average monthly" discharge limitation means the highest allowable average of "daily discharges" over a calendar month, calculated as the sum of all "daily discharges" measured during a calendar month divided by the number of "daily discharges" measured during that month. Compliance with fecal coliform bacteria or E coli bacteria limitations shall be determined using the geometric mean.

"85 percent removal" means the arithmetic mean of the values for effluent samples collected in a period of 30 consecutive days shall not exceed 15 percent of the arithmetic mean of the values for influent samples collected at approximately the same times during the same period.

"Absolute Limitations" Compliance with limitations having descriptions of "shall not be less than," "nor greater than," "shall not exceed," "minimum," or "maximum" shall be determined from any single value for effluent samples and/or measurements collected.

"Net concentration" shall mean the difference between the concentration of a given substance in a sample taken of the discharge and the concentration of the same substances in a sample taken at the intake which supplies water to the given process. For the purpose of this definition, samples that are taken to determine the net concentration shall always be 24-hour composite samples made up of at least six increments taken at regular intervals throughout the plant day.



"Net Load" shall mean the difference between the load of a given substance as calculated from a sample taken of the discharge and the load of the same substance in a sample taken at the intake which supplies water to given process. For purposes of this definition, samples that are taken to determine the net loading shall always be 24-hour composite samples made up of at least six increments taken at regular intervals throughout the plant day.

"MGD" means million gallons per day.

"mg/l" means milligrams per liter.

"ug/l" means micrograms per liter.

"ng/l" means nanograms per liter.

"S.U." means standard pH unit.

"kg/day" means kilograms per day.

"Reporting Code" is a five digit number used by the Ohio EPA in processing reported data. The reporting code does not imply the type of analysis used nor the sampling techniques employed.

"Quarterly (1/Quarter) sampling frequency" means the sampling shall be done in the months of March, June, August, and December, unless specifically identified otherwise in the Effluent Limitations and Monitoring Requirements table.

"Yearly (1/Year) sampling frequency" means the sampling shall be done in the month of September, unless specifically identified otherwise in the effluent limitations and monitoring requirements table.

"Semi-annual (2/Year) sampling frequency" means the sampling shall be done during the months of June and December, unless specifically identified otherwise.

"Winter" shall be considered to be the period from November 1 through April 30.

"Bypass" means the intentional diversion of waste streams from any portion of the treatment facility.

"Summer" shall be considered to be the period from May 1 through October 31.

"Severe property damage" means substantial physical damage to property, damage to the treatment facilities which would cause them to become inoperable, or substantial and permanent loss of natural resources which can reasonably be expected to occur in the absence of a bypass. Severe property damage does not mean economic loss caused by delays in production.

"Upset" means an exceptional incident in which there is unintentional and temporary noncompliance with technology based permit effluent limitations because of factors beyond the reasonable control of the permittee. An upset does not include noncompliance to the extent caused by operational error, improperly designed treatment facilities, inadequate treatment facilities, lack of preventive maintenance, or careless or improper operation.

"Sewage sludge" means a solid, semi-solid, or liquid residue generated during the treatment of domestic sewage in a treatment works as defined in section 6111.01 of the Revised Code. "Sewage sludge" includes, but is not limited to, scum or solids removed in primary, secondary, or advanced wastewater treatment processes. "Sewage sludge" does not include ash generated during the firing of sewage sludge in a sewage sludge incinerator, grit and screenings generated during preliminary treatment of domestic sewage in a treatment works, animal manure, residue generated during treatment of animal manure, or domestic septage.

"Sewage sludge weight" means the weight of sewage sludge, in dry U.S. tons, including admixtures such as liming materials or bulking agents. Monitoring frequencies for sewage sludge parameters are based on the reported sludge weight generated in a calendar year (use the most recent calendar year data when the NPDES permit is up for renewal).

"Sewage sludge fee weight" means the weight of sewage sludge, in dry U.S. tons, excluding admixtures such as liming materials or bulking agents. Annual sewage sludge fees, as per section 3745.11(Y) of the Ohio Revised Code, are based on the reported sludge fee weight for the most recent calendar year.

## 2. GENERAL EFFLUENT LIMITATIONS

The effluent shall, at all times, be free of substances:

- A. In amounts that will settle to form putrescent, or otherwise objectionable, sludge deposits; or that will adversely affect aquatic life or water fowl;
- B. Of an oily, greasy, or surface-active nature, and of other floating debris, in amounts that will form noticeable accumulations of scum, foam or sheen;
- C. In amounts that will alter the natural color or odor of the receiving water to such degree as to create a nuisance;
- D. In amounts that either singly or in combination with other substances are toxic to human, animal, or aquatic life;
- E. In amounts that are conducive to the growth of aquatic weeds or algae to the extent that such growths become inimical to more desirable forms of aquatic life, or create conditions that are unsightly, or constitute a nuisance in any other fashion;
- F. In amounts that will impair designated instream or downstream water uses.

## 3. FACILITY OPERATION AND QUALITY CONTROL

All wastewater treatment works shall be operated in a manner consistent with the following:

- A. At all times, the permittee shall maintain in good working order and operate as efficiently as possible all treatment or control facilities or systems installed or used by the permittee necessary to achieve compliance with the terms and conditions of this permit. Proper operation and maintenance also includes adequate laboratory controls and appropriate quality assurance procedures. This provision requires the operation of back-up or auxiliary facilities or similar systems which are installed by a permittee only when the operation is necessary to achieve compliance with conditions of the permit.
- B. The permittee shall effectively monitor the operation and efficiency of treatment and control facilities and the quantity and quality of the treated discharge.
- C. Maintenance of wastewater treatment works that results in degradation of effluent quality shall be scheduled during non-critical water quality periods and shall be carried out in a manner approved by Ohio EPA as specified in the Paragraph in the PART III entitled, "UNAUTHORIZED DISCHARGES".

## 4. REPORTING

A. Monitoring data required by this permit shall be submitted monthly on Ohio EPA 4500 Discharge Monitoring Report (DMR) forms using the electronic DMR (e-DMR) internet application. e-DMR allows permitted facilities to enter, sign, and submit DMRs on the internet. e-DMR information is found on the following web page:

<http://www.epa.ohio.gov/dsw/edmr/eDMR.aspx>

Alternatively, if you are unable to use e-DMR due to a demonstrated hardship, monitoring data may be submitted on paper DMR forms provided by Ohio EPA. Monitoring data shall be typed on the forms. Please contact Ohio EPA, Division of Surface Water at (614) 644-2050 if you wish to receive paper DMR forms.

B. DMRs shall be signed by a facility's Responsible Official or a Delegated Responsible Official (i.e. a person delegated by the Responsible Official). The Responsible Official of a facility is defined as:

1. For corporations - a president, secretary, treasurer, or vice-president of the corporation in charge of a principal business function, or any other person who performs similar policy or decision making functions for the corporation; or the manager of one or more manufacturing, production or operating facilities, provided the manager is authorized to make management decisions which govern the operation of the regulated facility including having explicit or implicit duty of making major capital investment recommendations, and initiating and directing other comprehensive measures to assure long-term environmental compliance with environmental laws and regulations; the manager can ensure that the necessary systems are established or actions taken to gather complete and accurate information for permit application requirements; and where authority to sign documents has been assigned or delegated to the manager in accordance with corporate procedures;
2. For partnerships - a general partner;
3. For a sole proprietorship - the proprietor; or,
4. For a municipality, state or other public facility - a principal executive officer, a ranking elected official or other duly authorized employee.

For e-DMR, the person signing and submitting the DMR will need to obtain an eBusiness Center account and Personal Identification Number (PIN). Additionally, Delegated Responsible Officials must be delegated by the Responsible Official, either on-line using the eBusiness Center's delegation function, or on a paper delegation form provided by Ohio EPA. For more information on the PIN and delegation processes, please view the following web page:

<http://epa.ohio.gov/dsw/edmr/eDMR.aspx>

C. DMRs submitted using e-DMR shall be submitted to Ohio EPA by the 20th day of the month following the month-of-interest. DMRs submitted on paper must include the original signed DMR form and shall be mailed to Ohio EPA at the following address so that they are received no later than the 15th day of the month following the month-of-interest:

Ohio Environmental Protection Agency  
Lazarus Government Center  
Division of Surface Water - PCU  
P.O. Box 1049  
Columbus, Ohio 43216-1049

D. If the permittee monitors any pollutant at the location(s) designated herein more frequently than required by this permit, using approved analytical methods as specified in Section 5. SAMPLING AND ANALYTICAL METHODS, the results of such monitoring shall be included in the calculation and reporting of the values required in the reports specified above.

E. Analyses of pollutants not required by this permit, except as noted in the preceding paragraph, shall not be reported to the Ohio EPA, but records shall be retained as specified in Section 7. RECORDS RETENTION.

#### 5. SAMPLING AND ANALYTICAL METHOD

Samples and measurements taken as required herein shall be representative of the volume and nature of the monitored flow. Test procedures for the analysis of pollutants shall conform to regulation 40 CFR 136, "Test Procedures For The Analysis of Pollutants" unless other test procedures have been specified in this permit. The permittee shall periodically calibrate and perform maintenance procedures on all monitoring and analytical instrumentation at intervals to insure accuracy of measurements.

#### 6. RECORDING OF RESULTS

For each measurement or sample taken pursuant to the requirements of this permit, the permittee shall record the following information:

- A. The exact place and date of sampling; (time of sampling not required on EPA 4500)
- B. The person(s) who performed the sampling or measurements;
- C. The date the analyses were performed on those samples;
- D. The person(s) who performed the analyses;
- E. The analytical techniques or methods used; and
- F. The results of all analyses and measurements.

#### 7. RECORDS RETENTION

The permittee shall retain all of the following records for the wastewater treatment works for a minimum of three years except those records that pertain to sewage sludge disposal, use, storage, or treatment, which shall be kept for a minimum of five years, including:

- A. All sampling and analytical records (including internal sampling data not reported);
- B. All original recordings for any continuous monitoring instrumentation;
- C. All instrumentation, calibration and maintenance records;
- D. All plant operation and maintenance records;
- E. All reports required by this permit; and
- F. Records of all data used to complete the application for this permit for a period of at least three years, or five years for sewage sludge, from the date of the sample, measurement, report, or application.

These periods will be extended during the course of any unresolved litigation, or when requested by the Regional Administrator or the Ohio EPA. The three year period, or five year period for sewage sludge, for retention of records shall start from the date of sample, measurement, report, or application.

#### 8. AVAILABILITY OF REPORTS

Except for data determined by the Ohio EPA to be entitled to confidential status, all reports prepared in accordance with the terms of this permit shall be available for public inspection at the appropriate district offices of the Ohio EPA. Both the Clean Water Act and Section 6111.05 Ohio Revised Code state that effluent data and receiving water quality data shall not be considered confidential.

#### 9. DUTY TO PROVIDE INFORMATION

The permittee shall furnish to the Director, within a reasonable time, any information which the Director may request to determine whether cause exists for modifying, revoking, and reissuing, or terminating the permit, or to determine compliance with this permit. The permittee shall also furnish to the Director, upon request, copies of records required to be kept by this permit.

#### 10. RIGHT OF ENTRY

The permittee shall allow the Director or an authorized representative upon presentation of credentials and other documents as may be required by law to:

- A. Enter upon the permittee's premises where a regulated facility or activity is located or conducted, or where records must be kept under the conditions of this permit.
- B. Have access to and copy, at reasonable times, any records that must be kept under the conditions of the permit.
- C. Inspect at reasonable times any facilities, equipment (including monitoring and control equipment), practices, or operations regulated or required under this permit.
- D. Sample or monitor at reasonable times, for the purposes of assuring permit compliance or as otherwise authorized by the Clean Water Act, any substances or parameters at any location.

## 11. UNAUTHORIZED DISCHARGES

A. Bypass Not Exceeding Limitations - The permittee may allow any bypass to occur which does not cause effluent limitations to be exceeded, but only if it also is for essential maintenance to assure efficient operation. These bypasses are not subject to the provisions of paragraphs 11.B and 11.C.

### B. Notice

1. Anticipated Bypass - If the permittee knows in advance of the need for a bypass, it shall submit prior notice, if possible at least ten days before the date of the bypass.

2. Unanticipated Bypass - The permittee shall submit notice of an unanticipated bypass as required in paragraph 12.B (24 hour notice).

### C. Prohibition of Bypass

1. Bypass is prohibited, and the Director may take enforcement action against a permittee for bypass, unless:

a. Bypass was unavoidable to prevent loss of life, personal injury, or severe property damage;

b. There were no feasible alternatives to the bypass, such as the use of auxiliary treatment facilities, retention of untreated wastes, or maintenance during normal periods of equipment downtime. This condition is not satisfied if adequate back-up equipment should have been installed in the exercise of reasonable engineering judgment to prevent a bypass which occurred during normal periods of equipment downtime or preventive maintenance; and

c. The permittee submitted notices as required under paragraph 11.B.

2. The Director may approve an anticipated bypass, after considering its adverse effects, if the Director determines that it will meet the three conditions listed above in paragraph 11.C.1.

## 12. NONCOMPLIANCE NOTIFICATION

### A. Exceedance of a Daily Maximum Discharge Limit

1. The permittee shall report noncompliance that is the result of any violation of a daily maximum discharge limit for any of the pollutants listed by the Director in the permit by e-mail or telephone within twenty-four (24) hours of discovery.

The permittee may report to the appropriate Ohio EPA district office e-mail account as follows (this method is preferred):

Southeast District Office: [sedo24hournpdes@epa.state.oh.us](mailto:sedo24hournpdes@epa.state.oh.us)  
Southwest District Office: [swdo24hournpdes@epa.state.oh.us](mailto:swdo24hournpdes@epa.state.oh.us)  
Northwest District Office: [nwdo24hournpdes@epa.state.oh.us](mailto:nwdo24hournpdes@epa.state.oh.us)  
Northeast District Office: [nedo24hournpdes@epa.state.oh.us](mailto:nedo24hournpdes@epa.state.oh.us)  
Central District Office: [cdo24hournpdes@epa.state.oh.us](mailto:cdo24hournpdes@epa.state.oh.us)  
Central Office: [co24hournpdes@epa.state.oh.us](mailto:co24hournpdes@epa.state.oh.us)

The permittee shall attach a noncompliance report to the e-mail. A noncompliance report form is available on the following web site under the Monitoring and Reporting - Non-Compliance Notification section:

<http://epa.ohio.gov/dsw/permits/individuals.aspx>

Or, the permittee may report to the appropriate Ohio EPA district office by telephone toll-free between 8:00 AM and 5:00 PM as follows:

Southeast District Office: (800) 686-7330  
Southwest District Office: (800) 686-8930  
Northwest District Office: (800) 686-6930  
Northeast District Office: (800) 686-6330  
Central District Office: (800) 686-2330  
Central Office: (614) 644-2001

The permittee shall include the following information in the telephone noncompliance report:

- a. The name of the permittee, and a contact name and telephone number;
- b. The limit(s) that has been exceeded;
- c. The extent of the exceedance(s);
- d. The cause of the exceedance(s);
- e. The period of the exceedance(s) including exact dates and times;
- f. If uncorrected, the anticipated time the exceedance(s) is expected to continue; and,
- g. Steps taken to reduce, eliminate or prevent occurrence of the exceedance(s).

**B. Other Permit Violations**

1. The permittee shall report noncompliance that is the result of any unanticipated bypass resulting in an exceedance of any effluent limit in the permit or any upset resulting in an exceedance of any effluent limit in the permit by e-mail or telephone within twenty-four (24) hours of discovery.

The permittee may report to the appropriate Ohio EPA district office e-mail account as follows (this method is preferred):

Southeast District Office: sedo24hournpdes@epa.state.oh.us  
Southwest District Office: swdo24hournpdes@epa.state.oh.us  
Northwest District Office: nwdo24hournpdes@epa.state.oh.us  
Northeast District Office: nedo24hournpdes@epa.state.oh.us  
Central District Office: cdo24hournpdes@epa.state.oh.us  
Central Office: co24hournpdes@epa.state.oh.us

The permittee shall attach a noncompliance report to the e-mail. A noncompliance report form is available on the following web site:

<http://www.epa.ohio.gov/dsw/permits/permits.aspx>

Or, the permittee may report to the appropriate Ohio EPA district office by telephone toll-free between 8:00 AM and 5:00 PM as follows:

Southeast District Office: (800) 686-7330  
Southwest District Office: (800) 686-8930  
Northwest District Office: (800) 686-6930  
Northeast District Office: (800) 686-6330  
Central District Office: (800) 686-2330  
Central Office: (614) 644-2001

The permittee shall include the following information in the telephone noncompliance report:

- a. The name of the permittee, and a contact name and telephone number;
  - b. The time(s) at which the discharge occurred, and was discovered;
  - c. The approximate amount and the characteristics of the discharge;
  - d. The stream(s) affected by the discharge;
  - e. The circumstances which created the discharge;
  - f. The name and telephone number of the person(s) who have knowledge of these circumstances;
  - g. What remedial steps are being taken; and,
  - h. The name and telephone number of the person(s) responsible for such remedial steps.
2. The permittee shall report noncompliance that is the result of any spill or discharge which may endanger human health or the environment within thirty (30) minutes of discovery by calling the 24-Hour Emergency Hotline toll-free at (800) 282-9378. The permittee shall also report the spill or discharge by e-mail or telephone within twenty-four (24) hours of discovery in accordance with B.1 above.
- C. When the telephone option is used for the noncompliance reports required by A and B, the permittee shall submit to the appropriate Ohio EPA district office a confirmation letter and a completed noncompliance report within five (5) days of the discovery of the noncompliance. This follow up report is not necessary for the e-mail option which already includes a completed noncompliance report.
- D. If the permittee is unable to meet any date for achieving an event, as specified in a schedule of compliance in their permit, the permittee shall submit a written report to the appropriate Ohio EPA district office within fourteen (14) days of becoming aware of such a situation. The report shall include the following:
1. The compliance event which has been or will be violated;
  2. The cause of the violation;
  3. The remedial action being taken;
  4. The probable date by which compliance will occur; and,
  5. The probability of complying with subsequent and final events as scheduled.
- E. The permittee shall report all other instances of permit noncompliance not reported under paragraphs A or B of this section on their monthly DMR submission. The DMR shall contain comments that include the information listed in paragraphs A or B as appropriate.
- F. If the permittee becomes aware that it failed to submit an application, or submitted incorrect information in an application or in any report to the director, it shall promptly submit such facts or information.

13. RESERVED

14. DUTY TO MITIGATE

The permittee shall take all reasonable steps to minimize or prevent any discharge in violation of this permit which has a reasonable likelihood of adversely affecting human health or the environment.



## 15. AUTHORIZED DISCHARGES

All discharges authorized herein shall be consistent with the terms and conditions of this permit. The discharge of any pollutant identified in this permit more frequently than, or at a level in excess of, that authorized by this permit shall constitute a violation of the terms and conditions of this permit. Such violations may result in the imposition of civil and/or criminal penalties as provided for in Section 309 of the Act and Ohio Revised Code Sections 6111.09 and 6111.99.

## 16. DISCHARGE CHANGES

The following changes must be reported to the appropriate Ohio EPA district office as soon as practicable:

A. For all treatment works, any significant change in character of the discharge which the permittee knows or has reason to believe has occurred or will occur which would constitute cause for modification or revocation and reissuance. The permittee shall give advance notice to the Director of any planned changes in the permitted facility or activity which may result in noncompliance with permit requirements. Notification of permit changes or anticipated noncompliance does not stay any permit condition.

B. For publicly owned treatment works:

1. Any proposed plant modification, addition, and/or expansion that will change the capacity or efficiency of the plant;

2. The addition of any new significant industrial discharge; and

3. Changes in the quantity or quality of the wastes from existing tributary industrial discharges which will result in significant new or increased discharges of pollutants.

C. For non-publicly owned treatment works, any proposed facility expansions, production increases, or process modifications, which will result in new, different, or increased discharges of pollutants.

Following this notice, modifications to the permit may be made to reflect any necessary changes in permit conditions, including any necessary effluent limitations for any pollutants not identified and limited herein. A determination will also be made as to whether a National Environmental Policy Act (NEPA) review will be required. Sections 6111.44 and 6111.45, Ohio Revised Code, require that plans for treatment works or improvements to such works be approved by the Director of the Ohio EPA prior to initiation of construction.

D. In addition to the reporting requirements under 40 CFR 122.41(l) and per 40 CFR 122.42(a), all existing manufacturing, commercial, mining, and silvicultural dischargers must notify the Director as soon as they know or have reason to believe:

1. That any activity has occurred or will occur which would result in the discharge on a routine or frequent basis of any toxic pollutant which is not limited in the permit. If that discharge will exceed the highest of the "notification levels" specified in 40 CFR Sections 122.42(a)(1)(i) through 122.42(a)(1)(iv).

2. That any activity has occurred or will occur which would result in any discharge, on a non-routine or infrequent basis, of a toxic pollutant which is not limited in the permit, if that discharge will exceed the highest of the "notification levels" specified in 122.42(a)(2)(i) through 122.42(a)(2)(iv).

## 17. TOXIC POLLUTANTS

The permittee shall comply with effluent standards or prohibitions established under Section 307 (a) of the Clean Water Act for toxic pollutants within the time provided in the regulations that establish these standards or prohibitions, even if the permit has not yet been modified to incorporate the requirement. Following establishment of such standards or prohibitions, the Director shall modify this permit and so notify the permittee.

#### 18. PERMIT MODIFICATION OR REVOCATION

A. After notice and opportunity for a hearing, this permit may be modified or revoked, by the Ohio EPA, in whole or in part during its term for cause including, but not limited to, the following:

1. Violation of any terms or conditions of this permit;
2. Obtaining this permit by misrepresentation or failure to disclose fully all relevant facts; or
3. Change in any condition that requires either a temporary or permanent reduction or elimination of the permitted discharge.

B. Pursuant to rule 3745-33-04, Ohio Administrative Code, the permittee may at any time apply to the Ohio EPA for modification of any part of this permit. The filing of a request by the permittee for a permit modification or revocation does not stay any permit condition. The application for modification should be received by the appropriate Ohio EPA district office at least ninety days before the date on which it is desired that the modification become effective. The application shall be made only on forms approved by the Ohio EPA.

#### 19. TRANSFER OF OWNERSHIP OR CONTROL

This permit may be transferred or assigned and a new owner or successor can be authorized to discharge from this facility, provided the following requirements are met:

A. The permittee shall notify the succeeding owner or successor of the existence of this permit by a letter, a copy of which shall be forwarded to the appropriate Ohio EPA district office. The copy of that letter will serve as the permittee's notice to the Director of the proposed transfer. The copy of that letter shall be received by the appropriate Ohio EPA district office sixty (60) days prior to the proposed date of transfer;

B. A written agreement containing a specific date for transfer of permit responsibility and coverage between the current and new permittee (including acknowledgement that the existing permittee is liable for violations up to that date, and that the new permittee is liable for violations from that date on) shall be submitted to the appropriate Ohio EPA district office within sixty days after receipt by the district office of the copy of the letter from the permittee to the succeeding owner;

At anytime during the sixty (60) day period between notification of the proposed transfer and the effective date of the transfer, the Director may prevent the transfer if he concludes that such transfer will jeopardize compliance with the terms and conditions of the permit. If the Director does not prevent transfer, he will modify the permit to reflect the new owner.

#### 20. OIL AND HAZARDOUS SUBSTANCE LIABILITY

Nothing in this permit shall be construed to preclude the institution of any legal action or relieve the permittee from any responsibilities, liabilities, or penalties to which the permittee is or may be subject under Section 311 of the Clean Water Act.

#### 21. SOLIDS DISPOSAL

Collected grit and screenings, and other solids other than sewage sludge, shall be disposed of in such a manner as to prevent entry of those wastes into waters of the state, and in accordance with all applicable laws and rules.

#### 22. CONSTRUCTION AFFECTING NAVIGABLE WATERS

This permit does not authorize or approve the construction of any onshore or offshore physical structures or facilities or the undertaking of any work in any navigable waters.

### 23. CIVIL AND CRIMINAL LIABILITY

Except as exempted in the permit conditions on UNAUTHORIZED DISCHARGES or UPSETS, nothing in this permit shall be construed to relieve the permittee from civil or criminal penalties for noncompliance.

### 24. STATE LAWS AND REGULATIONS

Nothing in this permit shall be construed to preclude the institution of any legal action or relieve the permittee from any responsibilities, liabilities, or penalties established pursuant to any applicable state law or regulation under authority preserved by Section 510 of the Clean Water Act.

### 25. PROPERTY RIGHTS

The issuance of this permit does not convey any property rights in either real or personal property, or any exclusive privileges, nor does it authorize any injury to private property or any invasion of personal rights, nor any infringement of federal, state, or local laws or regulations.

### 26. UPSET

The provisions of 40 CFR Section 122.41(n), relating to "Upset," are specifically incorporated herein by reference in their entirety. For definition of "upset," see Part III, Paragraph 1, DEFINITIONS.

### 27. SEVERABILITY

The provisions of this permit are severable, and if any provision of this permit, or the application of any provision of this permit to any circumstance, is held invalid, the application of such provision to other circumstances, and the remainder of this permit, shall not be affected thereby.

### 28. SIGNATORY REQUIREMENTS

All applications submitted to the Director shall be signed and certified in accordance with the requirements of 40 CFR 122.22.

All reports submitted to the Director shall be signed and certified in accordance with the requirements of 40 CFR Section 122.22.

### 29. OTHER INFORMATION

A. Where the permittee becomes aware that it failed to submit any relevant facts in a permit application or submitted incorrect information in a permit application or in any report to the Director, it shall promptly submit such facts or information.

B. ORC 6111.99 provides that any person who falsifies, tampers with, or knowingly renders inaccurate any monitoring device or method required to be maintained under this permit shall, upon conviction, be punished by a fine of not more than \$25,000 per violation.

C. ORC 6111.99 states that any person who knowingly makes any false statement, representation, or certification in any record or other document submitted or required to be maintained under this permit including monitoring reports or reports of compliance or noncompliance shall, upon conviction, be punished by a fine of not more than \$25,000 per violation.

D. ORC 6111.99 provides that any person who violates Sections 6111.04, 6111.042, 6111.05, or division (A) of Section 6111.07 of the Revised Code shall be fined not more than \$25,000 or imprisoned not more than one year, or both.

30. NEED TO HALT OR REDUCE ACTIVITY

40 CFR 122.41(c) states that it shall not be a defense for a permittee in an enforcement action that it would have been necessary to halt or reduce the permitted activity in order to maintain compliance with conditions of this permit.

31. APPLICABLE FEDERAL RULES

All references to 40 CFR in this permit mean the version of 40 CFR which is effective as of the effective date of this permit.

32. AVAILABILITY OF PUBLIC SEWERS

Notwithstanding the issuance or non-issuance of an NPDES permit to a semi-public disposal system, whenever the sewage system of a publicly owned treatment works becomes available and accessible, the permittee operating any semi-public disposal system shall abandon the semi-public disposal system and connect it into the publicly owned treatment works.

National Pollutant Discharge Elimination System (NPDES) Permit Program

FACT SHEET

Regarding an NPDES Permit to Discharge to Waters of the State of Ohio  
for City of Napoleon Wastewater Treatment Plant (WWTP)

Public Notice No.: 19-06-039  
Public Notice Date: June 20, 2019  
Comment Period Ends: July 20, 2019

Ohio EPA Permit No.: 2PD00000\*SD  
Application No.: OH0020893

Name and Address of Applicant:

City of Napoleon  
P.O. Box 151  
Napoleon, OH 43545

Name and Address of Facility Where

Discharge Occurs:

Napoleon WWTP  
735 East Washington Street  
Napoleon, OH 43545  
Henry County

Receiving Water: Maumee River

Subsequent Stream Network: Lake Erie

**INTRODUCTION**

Development of a Fact Sheet for NPDES permits is mandated by Title 40 of the Code of Federal Regulations (CFR), Section 124.8 and 124.56. This document fulfills the requirements established in those regulations by providing the information necessary to inform the public of actions proposed by the Ohio Environmental Protection Agency (Ohio EPA), as well as the methods by which the public can participate in the process of finalizing those actions.

This Fact Sheet is prepared in order to document the technical basis and risk management decisions that are considered in the determination of water quality based NPDES Permit effluent limitations. The technical basis for the Fact Sheet may consist of evaluations of promulgated effluent guidelines, existing effluent quality, instream biological, chemical and physical conditions, and the relative risk of alternative effluent limitations. This Fact Sheet details the discretionary decision-making process empowered to the Director by the Clean Water Act (CWA) and Ohio Water Pollution Control Law (Ohio Revised Code [ORC] 6111). Decisions to award variances to Water Quality Standards (WQS) or promulgated effluent guidelines for economic or technological reasons will also be justified in the Fact Sheet where necessary.

No antidegradation review was necessary.

Effluent limits based on available treatment technologies are required by Section 301(b) of the CWA. Many of these have already been established by the United States Environmental Protection Agency (U.S. EPA) in the effluent guideline regulations (a.k.a. categorical regulations) for industry categories in 40 CFR Parts 405-499. Technology-based regulations for publicly-owned treatment works are listed in the Secondary Treatment Regulations (40 CFR Part 133). If regulations have not been established for a category of dischargers, the director may establish technology-based limits based on best professional judgment (BPJ).

Ohio EPA reviews the need for water-quality-based limits on a pollutant-by-pollutant basis. Wasteload allocations (WLAs) are used to develop these limits based on the pollutants that have been detected in the

discharge, and the receiving water's assimilative capacity. The assimilative capacity depends on the flow in the water receiving the discharge, and the concentration of the pollutant upstream. The greater the upstream flow, and the lower the upstream concentration, the greater the assimilative capacity is. Assimilative capacity may represent dilution (as in allocations for metals), or it may also incorporate the break-down of pollutants in the receiving water (as in allocations for oxygen-demanding materials).

The need for water-quality-based limits is determined by comparing the WLA for a pollutant to a measure of the effluent quality. The measure of effluent quality is called Projected Effluent Quality (PEQ). This is a statistical measure of the average and maximum effluent values for a pollutant. As with any statistical method, the more data that exists for a given pollutant, the more likely that PEQ will match the actual observed data. If there is a small data set for a given pollutant, the highest measured value is multiplied by a statistical factor to obtain a PEQ; for example if only one sample exists, the factor is 6.2, for two samples - 3.8, for three samples - 3.0. The factors continue to decline as samples sizes increase. These factors are intended to account for effluent variability, but if the pollutant concentrations are fairly constant, these factors may make PEQ appear larger than it would be shown to be if more sample results existed.

## SUMMARY OF PERMIT CONDITIONS

Lower average monthly effluent limits are proposed for mercury as Napoleon WWTP continues to implement a pollutant minimization plan under a mercury variance.

Lower average weekly and monthly effluent limits are proposed for ammonia from June to September due to a reasonable potential to exceed the wasteload allocation (WLA)

Limits are proposed to be removed for copper due to a lack of reasonable potential to exceed the WLA. Monitoring is proposed to continue at the same frequency (monthly).

The effluent from Napoleon WWTP shows no acute toxicity and no chronic toxicity for *Pimephales promelas*. Annual monitoring is proposed for the life of the permit for *P. promelas*. Semi-annual determination of acute endpoints from chronic toxicity monitoring is proposed for *Ceriodaphnia dubia*. This satisfies the minimum testing requirements of Ohio Administrative Code (OAC) 3754-33-07(B)(11).

In accordance with OAC 3745-33-07, it has been determined that the effluent from Napoleon WWTP shows chronic toxicity for *C. dubia*. Limits of 2.21 TUC, semi-annual monitoring, and a 54-month compliance schedule are proposed; see Part I,C Item A and Part II Item AA.5 for details, including a condition which triggers a Toxicity Reduction Evaluation (TRE) if the proposed limit is exceeded during the interim period.

New monitoring for total Kjeldahl nitrogen is proposed for station 001 to provide data for a future TMDL study.

New monitoring for nitrate plus nitrite, total Kjeldahl nitrogen, and phosphorus is proposed at upstream station 801 and downstream station 901 to provide nutrient data for a future TMDL study.

Monitoring for *E. coli* at stations 801 and 901 is proposed to change from summer to June-August and from monthly to once per two weeks, which will facilitate impairment assessments in the receiving stream.

A schedule is proposed for implementation of the Wet Weather Improvement Plan. See Part I,C for details.

In Part II of the permit, special conditions are included that address CSO public notification; sanitary sewer overflow (SSO) reporting; operator certification, minimum staffing and operator of record; whole effluent toxicity (WET) testing; storm water compliance; mercury variance; toxicity reduction evaluation (TRE) trigger; downstream public water supply notification; and outfall signage.

## Table of Contents

	Page
INTRODUCTION.....	1
SUMMARY OF PERMIT CONDITIONS .....	2
PROCEDURES FOR PARTICIPATION IN THE FORMULATION OF FINAL DETERMINATIONS .....	4
INFORMATION REGARDING CERTAIN WATER QUALITY BASED EFFLUENT LIMITS .....	4
LOCATION OF DISCHARGE/RECEIVING WATER USE CLASSIFICATION.....	6
FACILITY DESCRIPTION.....	6
DESCRIPTION OF EXISTING DISCHARGE .....	7
ASSESSMENT OF IMPACT ON RECEIVING WATERS .....	8
DEVELOPMENT OF WATER-QUALITY-BASED EFFLUENT LIMITS .....	9
REASONABLE POTENTIAL/EFFLUENT LIMITS/MANAGEMENT DECISIONS .....	10
OTHER REQUIREMENTS.....	14

## List of Figures

Figure 1. Location of Napoleon WWTP. ....	16
Figure 2. Diagram of Wastewater Treatment System .....	17

## List of Tables

Table 1. Sewage Sludge Removal.....	18
Table 2. Average Annual Effluent Flow Rates .....	18
Table 3. Sanitary Sewer Overflows Discharges .....	18
Table 4. Combined Sewer Overflow Discharges from Mar. 2014 – Dec. 2018 .....	19
Table 5. Bypass Discharges via EQ Basin Overflow .....	19
Table 6. Napoleon WWTP Phosphorus Loading, compared to Annex 4 Target (2008).....	19
Table 7. Effluent Characterization by Ohio EPA and Napoleon WWTP. ....	20
Table 8. Effluent Characterization using electronic Monthly Discharge Reports (eDMR) .....	21
Table 9. Projected Effluent Quality for Outfall 001 .....	23
Table 10. Summary of Acute and Chronic Toxicity Results .....	24
Table 11. Aquatic Life and Recreational Use Attainment Table .....	25
Table 12. Water Quality Criteria in the Study Area.....	26
Table 13. Instream and Discharger Flows.....	27
Table 14. Background Water Quality .....	28
Table 15. Summary of Effluent Limits to Maintain Applicable Water Quality Criteria .....	29
Table 16. Parameter Assessment.....	30
Table 17. Final Effluent Limits for Outfall 001 .....	31

## List of Addendums

Addendum 1. Whole Effluent Toxicity Reasonable Potential Calculation .....	33
Addendum 2. Acronyms .....	34

## **PROCEDURES FOR PARTICIPATION IN THE FORMULATION OF FINAL DETERMINATIONS**

The draft action shall be issued as a final action unless the Director revises the draft after consideration of the record of a public meeting or written comments, or upon disapproval by the Administrator of the U.S. Environmental Protection Agency.

Within thirty days of the date of the Public Notice, any person may request or petition for a public meeting for presentation of evidence, statements or opinions. The purpose of the public meeting is to obtain additional evidence. Statements concerning the issues raised by the party requesting the meeting are invited. Evidence may be presented by the applicant, the state, and other parties, and following presentation of such evidence other interested persons may present testimony of facts or statements of opinion.

Requests for public meetings shall be in writing and shall state the action of the Director objected to, the questions to be considered, and the reasons the action is contested. Such requests should be addressed to:

**Legal Records Section  
Ohio Environmental Protection Agency  
P.O. Box 1049  
Columbus, Ohio 43216-1049**

Interested persons are invited to submit written comments upon the discharge permit. Comments should be submitted in person or by mail no later than 30 days after the date of this Public Notice. Deliver or mail all comments to:

**Ohio Environmental Protection Agency  
Attention: Division of Surface Water  
Permits Processing Unit  
P.O. Box 1049  
Columbus, Ohio 43216-1049**

The Ohio EPA permit number and Public Notice numbers should appear on each page of any submitted comments. All comments received no later than 30 days after the date of the Public Notice will be considered.

Citizens may conduct file reviews regarding specific companies or sites. Appointments are necessary to conduct file reviews, because requests to review files have increased dramatically in recent years. The first 250 pages copied are free. For requests to copy more than 250 pages, there is a five-cent charge for each page copied. Payment is required by check or money order, made payable to Treasurer State of Ohio.

For additional information about this fact sheet or the draft permit, contact David Brumbaugh, (614) 644-2138, david.brumbaugh@epa.ohio.gov.

## **INFORMATION REGARDING CERTAIN WATER QUALITY BASED EFFLUENT LIMITS**

This draft permit may contain proposed water-quality-based effluent limits (WQBELs) for parameters that **are not** priority pollutants. (See the following link for a list of the priority pollutants: [http://epa.ohio.gov/portals/35/pretreatment/Pretreatment\\_Program\\_Priority\\_Pollutant\\_Detection\\_Limits.pdf](http://epa.ohio.gov/portals/35/pretreatment/Pretreatment_Program_Priority_Pollutant_Detection_Limits.pdf).) In accordance with ORC 6111.03(J)(3), the Director established these WQBELs after considering, to the extent consistent with the Federal Water Pollution Control Act, evidence relating to the technical feasibility and economic reasonableness of removing the polluting properties from those wastes and to evidence relating to conditions calculated to result from that action and their relation to benefits to the people of the state and to accomplishment of the purposes of this chapter. This determination was made based on data and information



available at the time the permit was drafted, which included the contents of the timely submitted NPDES permit renewal application, along with any and all pertinent information available to the Director.

This public notice allows the permittee to provide to the Director for consideration during this public comment period additional site-specific pertinent and factual information with respect to the technical feasibility and economic reasonableness for achieving compliance with the proposed final effluent limitations for these parameters. The permittee shall deliver or mail this information to:

**Ohio Environmental Protection Agency  
Attention: Division of Surface Water  
Permits Processing Unit  
P.O. Box 1049  
Columbus, Ohio 43216-1049**

Should the applicant need additional time to review, obtain or develop site-specific pertinent and factual information with respect to the technical feasibility and economic reasonableness of achieving compliance with these limitations, a written request for any additional time shall be sent to the above address no later than 30 days after the Public Notice Date on Page 1.

Should the applicant determine that compliance with the proposed WQBELs for parameters other than the priority pollutants is technically and/or economically unattainable, the permittee may submit an application for a variance to the applicable WQS used to develop the proposed effluent limitation in accordance with the terms and conditions set forth in OAC 3745-33-07(D). The permittee shall submit this application to the above address no later than 30 days after the Public Notice Date.

Alternately, the applicant may propose the development of site-specific WQS pursuant to OAC 3745-1-39. The permittee shall submit written notification regarding their intent to develop site specific WQS for parameters that are not priority pollutants to the above address no later than 30 days after the Public Notice Date.

## LOCATION OF DISCHARGE/RECEIVING WATER USE CLASSIFICATION

Napoleon WWTP discharges to Maumee River at River Mile 46.05. Figure 1 shows the approximate location of the facility.

This segment of the Maumee River is described by Ohio EPA River Code: 04-001, Hydrologic Unit Code: 04100009-02-06, County: Henry, Ecoregion: Huron-Erie Lake Plain. The Maumee River is designated for the following uses under Ohio's WQS (OAC 3745-1-11): Modified Warmwater Habitat, Agricultural Water Supply, Industrial Water Supply, and Primary Contact Recreation. There is a public water supply within 500 yards of the discharge located at RM 45.88 and RM 47.13.

Use designations define the goals and expectations of a waterbody. These goals are set for aquatic life protection, recreation use and water supply use, and are defined in the Ohio WQS (OAC 3745-1-07). The use designations for individual waterbodies are listed in rules -08 through -32 of the Ohio WQS. Once the goals are set, numeric WQS are developed to protect these uses. Different uses have different water quality criteria.

## FACILITY DESCRIPTION

Napoleon WWTP was constructed in 1958 and last upgraded in 1998. The average design flow is 2.5 million gallons per day (MGD), the sustainable peak hydraulic capacity is 4.5 MGD, and the instantaneous peak hydraulic capacity is 6 MGD. Napoleon WWTP serves the City of Napoleon, a population of approximately 8750. Napoleon WWTP has the following treatment processes which are shown on Figure 2:

- Influent pumping
- Bar screen
- Grit removal
- Primary sedimentation
- Attached growth biotowers
- Activated sludge contact tank
- Alum addition
- Post aeration
- Secondary clarification
- Ultraviolet (UV)

When flow exceeds 6 MGD, flow is diverted from the WWTP influent to a 2.5 MG equalization (EQ) tank outside the headworks. Wastewater is stored and released to the WWTP for full treatment when flows subside. If flows above WWTP capacity continue after the EQ tank is full, an EQ overflow with a peak capacity of 11 MGD is activated and reported under monitoring station 603. EQ overflows are blended with secondary treatment effluent prior to disinfection via UV and discharged to the Maumee River via outfall 001. Any flows that exceed the capacity of the WWTP and EQ overflow are discharged via CSO 011 and blended with final effluent after UV but prior to reaching the Maumee River.

The City of Napoleon has 90% separated sewers and 10% combined sewers in the collection system. The City of Napoleon is implementing the City of Napoleon WWTP Wet Weather Improvement Plan, submitted June 20, 2018, amended March 20, 2019, and approved by Ohio EPA on May 27, 2019. The permit includes a compliance schedule to reduce combined sewer overflow (CSO) occurrences to five or fewer events per typical year and eliminate two remaining sanitary sewer overflows (SSO).

The City of Napoleon does not have an approved pretreatment program. The City has twenty-one industrial users that discharge a total of 0.901 MGD to the WWTP, including one noncategorical significant user that discharges 0.035 MGD and one categorical user that discharges 0.038 MGD.

Napoleon WWTP utilizes the following sewage sludge treatment processes (Figure 3):

- Anaerobic digestion
- Polymer, lime, ferric chloride alum addition
- Filter press
- Air drying

Treated sludge is land applied or disposed of in a landfill. Table 1 shows the last five years of sludge removed from Napoleon WWTP.

### **Storm Water Compliance**

To comply with industrial storm water regulations, the permittee submitted a form for "No Exposure Certification" which was signed on December 21, 2018. The certification number is 2GRN00632\*AG.

### **DESCRIPTION OF EXISTING DISCHARGE**

Napoleon WWTP had a single violation for oil & grease in 2015. This violation was not caused by a known process error or upset condition.

Napoleon WWTP estimates there is an infiltration/inflow (I/I) rate to the collection system of 0.3 MGD. The average annual effluent flow rate for Napoleon WWTP for the previous five years is presented on Table 2.

Napoleon WWTP reports SSOs at stations 300, 302, and 303. The number of SSOs is presented on Table 3. Stations 302 and 303 have been designated for Riverview Avenue intersects Haley Avenue (302) and Glenwood Avenue (303), where SSOs have historically occurred frequently. Two additional SSO outfalls, the parking lot at 303 West Main Street (2PD00000304) and the intersection of East Maumee Avenue and Cliff Street (2PD00000305), have been removed from the permit, due to control of overflows. Future overflows at these locations will be reported in Station 300.

The number of CSOs is presented on Table 4. As part of the LTCP, Napoleon WWTP has installed equalization storage and implemented I/I removal projects. To further reduce CSOs and eliminate SSOs, Napoleon WWTP plans to make improvements to pump stations and interceptors, employ additional equalization storage, and upgrade the WWTP headworks as part of the Wet Weather Improvement Plan.

Napoleon WWTP reports bypasses via the EQ basin overflow at station 603. The number of bypasses is presented in Table 5.

Table 6 presents chemical specific data compiled from data reported in priority pollutant scans conducted by Napoleon WWTP and data collected by Ohio EPA.

Table 7 presents a summary of unaltered Discharge Monitoring Report (DMR). Data are presented for the period March 2014 to December 2018 and current permit limits are provided for comparison.

Table 8 summarizes the chemical specific data for outfall 001 by presenting average and maximum PEQ values.

Table 9 summarizes the results of acute and chronic WET tests of the final effluent.

## ASSESSMENT OF IMPACT ON RECEIVING WATERS

The Lower Maumee watershed assessment unit, which includes the Maumee River in the vicinity of Napoleon WWTP, is listed as impaired for recreation and aquatic life uses on Ohio's 303(d) list. The attainment status of Maumee River is reported in the Final Ohio *2018 Integrated Water Quality Monitoring and Assessment Report*. The most recent data available for Maumee River is from 2012 and 2013 and was published in the Technical Support Document (TSD) *Biological and water Quality Study of the Maumee River and Auglaize River 2012-2013*. Based on this recent data, Ohio EPA documented impairment of aquatic life use caused by nutrients/eutrophication and flow regime alterations in the two large river assessment units downstream of the Napoleon WWTP (see Table 11). This impairment was determined by field assessments of the Maumee River approximately 15 miles downstream of Napoleon WWTP.

The TSD identifies the Grand Rapids Dams impoundment as one of the sources of the impairment. The river downstream of the dams has eroded down to bedrock, thus the channel's erosive energy has caused excessive widening. The widening resulted in decreased flow velocity, as well as relatively shallow depths which, paired with a downward trend in suspended solids, has led to increased light availability throughout the water column. These geomorphological characteristics result in excess benthic algal growth which depresses local macroinvertebrate populations when combined with the nutrient concentrations present in the Maumee River.

Napoleon WWTP did not have any violations of its phosphorus limits during the previous permit cycle. The facility's long term average concentration is 0.57 mg/L annually and 0.56 mg/L during the recreational season (see Table 5). The average annual phosphorus load discharged by Napoleon WWTP over the previous three years (1.191 mta) represents a 15% reduction in annual load compared to a baseline three-year average from 2008-2010 (1.368 mta). Napoleon WWTP contributes a very small portion (0.05%) of the total nutrient load in the Maumee River, which averaged 2212 mta<sup>1</sup>. Further, the Maumee River is in full attainment immediately downstream of the facility.

Despite the facility's improving performance, preliminary modelling efforts of the middle Maumee River shows that Napoleon WWTP, among several other point sources, contributes to the impairment below the Grand Rapids Dams. Further development of this modelling work may lead to a more restrictive total phosphorus limit for Napoleon WWTP than is proposed in this permit. However, these modeling efforts were focused on the near-field impairment at and downstream of Grand Rapids. They did not account for the far-field impairments in Lake Erie; for instance, impairments caused by harmful algal blooms. Before imposing additional requirements, Ohio EPA plans to develop a model to evaluate the reductions necessary to address the far-field impairments and combine the approaches into a more comprehensive strategy for addressing both impairments. Until Ohio EPA develops this strategy, the City of Napoleon should continue to search for and mitigate phosphorus sources, as well as optimize operations to reduce phosphorus discharge.

Based on the recent data presented in the TSD, the Maumee River is impaired for recreational use approximately 15 miles downstream. The identified sources are failing home sewage treatment systems and waterfowl accumulation. Napoleon WWTP did not have any violations of its *E. coli* limits during the previous permit cycle and the Maumee River is in full attainment immediately downstream of the facility. Napoleon WWTP is continuing to implement its LTCP to reduce CSO and SSO discharges to the Maumee River.

The full Integrated Report is available through the Ohio EPA, Division of Surface Water website at: <https://epa.ohio.gov/dsw/tmdl/OhioIntegratedReport>

The TSD is available through the Ohio EPA, Division of Surface Water website at: [https://epa.ohio.gov/Portals/35/documents/MaumeeTSD\\_2014.pdf](https://epa.ohio.gov/Portals/35/documents/MaumeeTSD_2014.pdf)

<sup>1</sup>Nutrient Mass Balance Study for Ohio's Major Rivers, 2018

## DEVELOPMENT OF WATER-QUALITY-BASED EFFLUENT LIMITS

Determining appropriate effluent concentrations is a multiple-step process in which parameters are identified as likely to be discharged by a facility, evaluated with respect to Ohio water quality criteria, and examined to determine the likelihood that the existing effluent could violate the calculated limits.

### Parameter Selection

Effluent data for the Napoleon WWTP were used to determine what parameters should undergo WLA. The parameters discharged are identified by the data available to Ohio EPA, DMR data submitted by the permittee, compliance sampling data collected by Ohio EPA, and any other data submitted by the permittee, such as priority pollutant scans required by the NPDES application or by pretreatment, or other special conditions in the NPDES permit. The sources of effluent data used in this evaluation are as follows:

Self-monitoring data (DMR)	March 2014 through December 2018
Ohio EPA compliance sampling data	2018
Napoleon WWTP pollutant scan	2018

### Statistical Outliers and Other Non-representative Data

The data were examined and the following values were removed from the evaluation as non-representative data:

- Copper – 8/8/2014 (129 µg/L) – value is an order of magnitude larger than the next value.
- Total filterable residue – 8/5/2016 (8 mg/L) – value is two orders of magnitude smaller than the next value

This data is evaluated statistically, and PEQ values are calculated for each pollutant. Average PEQ (PEQ<sub>avg</sub>) values represent the 95<sup>th</sup> percentile of monthly average data, and maximum PEQ (PEQ<sub>max</sub>) values represent the 95<sup>th</sup> percentile of all data points (see 8).

The PEQ values are used according to Ohio rules to compare to applicable WQS and allowable WLA values for each pollutant evaluated. Initially, PEQ values are compared to the applicable average and maximum WQS. If both PEQ values are less than 25 percent of the applicable WQS, the pollutant does not have the reasonable potential to cause or contribute to exceedances of WQS, and no WLA is done for that parameter. If either PEQ<sub>avg</sub> or PEQ<sub>max</sub> is greater than 25 percent of the applicable WQS, a WLA is conducted to determine whether the parameter exhibits reasonable potential and needs to have a limit or if monitoring is required (see Table 12).

### Wasteload Allocation

For those parameters that require a WLA, the results are based on the uses assigned to the receiving waterbody in OAC 3745-1. Dischargers are allocated pollutant loadings/concentrations based on the Ohio WQS (OAC 3745-1). Most pollutants are allocated by a mass balance method because they do not degrade in the receiving water. WLAs using this method are done using the following general equation: Discharger WLA = (downstream flow x WQS) - (upstream flow x background concentration). Discharger WLAs are divided by the discharge flow so that the allocations are expressed as concentrations. The assimilative capacity of the Maumee River was distributed between the Napoleon WWTP and Campbell Soup because the two facilities are close enough together that the pollutants discharged by the two facilities are interactive. WLA has been done in two parts; one part for common parameters of both Napoleon WWTP and Campbell Soup and the other part for parameters only of Napoleon WWTP.

The applicable waterbody uses for this facility's discharge and the associated stream design flows are as follows:

Aquatic life (Modified Warmwater Habitat)		
Toxics (metals, organics, etc.)	Average	Annual 7Q10
	Maximum	Annual 1Q10
Ammonia	Average	Summer 30Q10
		Winter 30Q10
Wildlife		Annual 90Q10
Agricultural Water Supply		Harmonic mean flow
Human Health (nondrinking)		Harmonic mean flow

Allocations are developed using a percentage of stream design flow as specified in Table 13, and allocations cannot exceed the Inside Mixing Zone Maximum (IMZM) criteria.

The data used in the WLA are listed in Tables 12 and 13. The WLA results to maintain all applicable criteria are presented in Table 15.

**Whole Effluent Toxicity Wasteload Allocation**

WET is the total toxic effect of an effluent on aquatic life measured directly with a toxicity test. Acute WET measures short term effects of the effluent while chronic WET measures longer term and potentially more subtle effects of the effluent.

WQS for WET are expressed in Ohio’s narrative “free from” WQS rule [OAC 3745-1-04(D)]. These “free froms” are translated into toxicity units (TUs) by the associated WQS Implementation Rule (OAC 3745-2-09). WLAs can then be calculated using TUs as if they were water quality criteria.

The WLA calculations for WET are similar to those for aquatic life criteria - using the chronic toxicity unit (TU<sub>c</sub>) and 7Q10 flow for the average and the acute toxicity unit (TU<sub>a</sub>) and 1Q10 flow for the maximum. These values are the levels of effluent toxicity that should not cause instream toxicity during critical low-flow conditions. For Napoleon WWTP, the WLA values are 1.0 TU<sub>a</sub> and 2.21 TU<sub>c</sub>.

The chronic toxicity unit (TU<sub>c</sub>) is defined as 100 divided by the estimate of the effluent concentration which causes a 25% reduction in growth or reproduction of test organisms (IC<sub>25</sub>):

$$TU_c = 100/IC_{25}$$

This equation applies outside the mixing zone for warmwater, modified warmwater, exceptional warmwater, coldwater, and seasonal salmonid use designations except when the following equation is more restrictive (*Ceriodaphnia dubia* only):

$$TU_c = 100/\text{geometric mean of No Observed Effect Concentration and Lowest Observed Effect Concentration}$$

The acute toxicity unit (TU<sub>a</sub>) is defined as 100 divided by the concentration in water having 50% chance of causing death to aquatic life (LC<sub>50</sub>) for the most sensitive test species:

$$TU_a = 100/LC_{50}$$

This equation applies outside the mixing zone for warmwater, modified warmwater, exceptional warmwater, coldwater, and seasonal salmonid use designations.

**REASONABLE POTENTIAL/EFFLUENT LIMITS/MANAGEMENT DECISIONS**

After appropriate effluent limits are calculated, the reasonable potential of the discharger to violate the WQS must be determined. Each parameter is examined and placed in a defined "group". Parameters that do not have

a WQS or do not require a WLA based on the initial screening are assigned to either group 1 or 2. For the allocated parameters, the preliminary effluent limits (PEL) based on the most restrictive average and maximum WLAs are selected from Table 15. The average PEL (PEL<sub>avg</sub>) is compared to the average PEQ (PEQ<sub>avg</sub>) from Table 9, and the PEL<sub>max</sub> is compared to the PEQ<sub>max</sub>. Based on the calculated percentage of the allocated value [(PEQ<sub>avg</sub> ÷ PEL<sub>avg</sub>) X 100, or (PEQ<sub>max</sub> ÷ PEL<sub>max</sub>) X 100], the parameters are assigned to group 3, 4, or 5. The groupings are listed in Table 16.

The final effluent limits are determined by evaluating the groupings in conjunction with other applicable rules and regulations. Table 17 presents the final effluent limits and monitoring requirements proposed for Napoleon WWTP outfall 001 and the basis for their recommendation. Unless otherwise indicated, the monitoring frequencies proposed in the permit are continued from the existing permit.

#### **Ammonia**

Lower limits are proposed for ammonia (June-Sept) based on the WLA. The limits proposed for ammonia (Oct-Nov) and ammonia (Dec-May) are all based on plant design criteria and protective of WQS.

#### **Dissolved Oxygen, Total Suspended Solids, and CBOD5**

The limits proposed for dissolved oxygen (DO) and summer 5-day carbonaceous biochemical oxygen demand (CBOD5) are all based on plant design criteria. The DO limits are protective of WQS.

The limits recommended for total suspended solids and winter 5-day carbonaceous biochemical oxygen demand (CBOD5) are technology-based treatment standards included in 40 CFR Part 133, Secondary Treatment Regulation. Secondary treatment is defined by the Best Practicable Waste Treatment Technology criteria, which are minimum standards required of all publicly owned treatment works. Summer CBOD5 limits are based on plant design.

#### ***E. coli*, Oil & Grease, and pH**

Limits proposed for oil and grease, pH, and *Escherichia coli* are based on WQS (OAC 3745-1-35 and 37). Primary contact recreation *E. coli* standards apply to the Maumee River.

#### **Total Filterable Residue**

The Ohio EPA risk assessment (Table 16) places total filterable residue in group 4. This placement, as well as the data in Table 8 and 9, support that these parameters do not have the reasonable potential to contribute to WQS exceedances, and limits are not necessary to protect water quality. Monitoring for Group 4 pollutants (where PEQ exceeds 50 percent of the WLA) is required by OAC 3745-33-07(A)(2). Monthly monitoring is proposed to continue.

#### **Cadmium, Chromium, Copper, Dissolved Hexavalent Chromium, Lead, Nickel, Nitrate plus Nitrite, and Zinc**

The Ohio EPA risk assessment (Table 16) places these parameters in groups 2 and 3. This placement, as well as the data in Table 8 and 9, support that these parameters do not have the reasonable potential to contribute to WQS exceedances, and limits are not necessary to protect water quality. Limits for copper are proposed to be removed. Monitoring for all parameters is proposed to continue at the same frequency.

#### **Antimony, Arsenic, Chloroform, Methyl Chloride, Molybdenum, Selenium, Thallium, and Toluene**

The Ohio EPA risk assessment (Table 16) places these parameters in groups 2 and 3. This placement, as well as the data in Tables 8 and 9, support that these parameters do not have the reasonable potential to contribute to WQS exceedances, and limits are not necessary to protect water quality. No new monitoring is proposed.

### **Flow Rate and Water Temperature**

Monitoring for flow rate and water temperature is proposed to continue in order to evaluate the performance of the treatment plant.

### **Rainfall**

Operations at Napoleon WWTP are directly impacted by precipitation due to the combined sewer system, therefore rainfall is proposed to be monitored due to best technical judgement.

### **Total Kjeldahl Nitrogen**

The TSD lists the Maumee River watershed as partially impaired for aquatic life downstream of Napoleon WWTP and nutrients and eutrophication are listed as causes. Though Napoleon WWTP is not identified as a source, considering the fact that municipal WWTPs discharge a nutrient load to the river, monthly monitoring for total Kjeldahl nitrogen is proposed based on best technical judgment. The purpose of the monitoring is to maintain a nutrient data set for use in the future total maximum daily loads (TMDL) study.

### **Phosphorus**

Phosphorus is limited based on provisions of OAC 3745-33-06(C).

### **Dissolved Orthophosphate**

Monitoring for dissolved orthophosphate (as P) is required by Ohio Senate Bill 1 (ORC 6111.03), which was signed by the Governor on April 2, 2015. Monitoring for orthophosphate will further develop nutrient datasets for dissolved reactive phosphorus that are used in stream and watershed assessments and studies. Because Ohio EPA monitoring, as well as other in-stream monitoring, is taken by grab sample, grab samples are proposed for orthophosphate to maintain consistent data. The grab samples must be filtered within 15 minutes of collection using a 0.45-micron filter. The filtered sample must be analyzed within 48 hours.

### **Mercury Variance**

The Ohio EPA risk assessment (Table 16) places mercury in group 5. This placement, as well as the data in Tables 8 and 9, indicates that the reasonable potential to exceed WQS exists and limits are necessary to protect water quality.

The Napoleon WWTP permit was renewed in July 2009 to include a mercury variance, and variance-based limits for mercury. Based on the monitoring results from March 2014 to December 2018, and the new application information, the Napoleon WWTP has determined that the facility will not meet the 30-day average permit limit of 1.3 ng/l. However, the effluent data shows that the permittee can meet the mercury annual average value of 12 ng/l. The permittee's application has also demonstrated to the satisfaction of Ohio EPA that there is no readily apparent means of complying with the WQBEL without constructing prohibitively expensive end-of-pipe controls for mercury. Based upon these demonstrations, the Napoleon WWTP is eligible for the mercury variance under OAC 3745-33-07(D)(10)(a).

Napoleon WWTP submitted information supporting the renewal of the variance. The permittee accepts and recycles computers and printers and has distributed surveys and educational materials to area dentists to reduce the amount of mercury coming being discharged. The calculation of the  $PEQ_{max}$  value from 2014 to 2018 compared to the  $PEQ_{avg}$  calculated at the time the original variance was issued shows a reduction from 19.6 ng/L to 4.2 ng/L. The Pollutant Minimization Program (PMP) schedule developed from the original variance continues to be implemented, and further reductions in mercury may be possible.

Ohio EPA has reviewed the mercury variance application and has determined that it meets the requirements of the OAC. A condition in Part II of the NPDES permit lists the provisions of the mercury variance, and includes the following requirements:



- A variance-based monthly average effluent limit of 4.2 ng/l, which was developed from sampling data submitted by the permittee;
- A requirement that the permittee make reasonable progress to meet the WQBEL for mercury by implementing the plan of study, which has been developed as part of the PMP;
- Low-level mercury monitoring of the plant's influent and effluent;
- A requirement that the annual average mercury effluent concentration is less than or equal to 12 ng/l as specified in the plan of study;
- A summary of the elements of the plan of study;
- A requirement to submit an annual report on implementation of the PMP; and
- A requirement for submittal of a certification stating that all permit conditions related to implementing the plan of study and the PMP have been satisfied, but that compliance with the monthly average WQBEL for mercury has not been achieved.

### **Whole Effluent Toxicity Reasonable Potential**

Evaluating the chronic toxicity results for *Ceriodaphnia dubia* in Table 9 under the provisions of 40 CFR Part 132, Appendix F, Procedure 6, gives a chronic PEQ of 15.41 TU<sub>c</sub> (Addendum 1). Reasonable potential for toxicity is demonstrated, since this value exceeds the WLA value of 2.21 TU<sub>c</sub>. Consistent with Procedure 6 and OAC 3745-33-07(B), a monthly average limit of 2.21 TU<sub>c</sub> is proposed. It is proposed that the final effluent limits for toxicity become effective 54 months from the effective date of the permit. Monitoring twice per year with a trigger to conduct a toxicity reduction evaluation (TRE) is proposed as the interim condition.

The acute toxicity results for *C. dubia* and *Pimephales promelas*, as well as chronic toxicity results for *P. promelas* in Table 9 show that there have been no detections of toxicity. Under the provisions of 40 CFR Part 132, Appendix F, Procedure 6, no PEQ values can be calculated. Reasonable potential for toxicity is not demonstrated. While this indicates that the plant's effluent does not currently pose a toxicity problem, annual toxicity testing is proposed consistent with the minimum monitoring requirements at OAC 3754-33-07(B)(11). Annual monitoring and the determination of acute endpoints from chronic toxicity monitoring is proposed for the life of the permit for *P. promelas*. Semi-annual determination of acute endpoints from chronic toxicity monitoring is proposed for the life of the permit for *C. dubia*. The proposed monitoring will adequately characterize toxicity in the plant's effluent.

### **Additional Monitoring Requirements**

New monitoring for nitrate plus nitrite, total Kjeldahl nitrogen, and phosphorus is being proposed at upstream monitoring station 801 and downstream monitoring station 901 to provide nutrient data for a future TMDL study.

Monitoring for *E. coli* at upstream monitoring station 801 and downstream monitoring station 901 is proposed to change from summer to June-August and from monthly to once every two weeks. The higher frequency over a shorter period will facilitate impairment assessments in the receiving stream.

Additional monitoring requirements proposed at the final effluent, influent and upstream/downstream stations are included for all facilities in Ohio and vary according to the type and size of the discharge. In addition to permit compliance, this data is used to assist in the evaluation of effluent quality and treatment plant performance and for designing plant improvements and conducting future stream studies.

### **Sludge**

Limits and monitoring requirements proposed for the disposal of sewage sludge by the following management practices are based on OAC 3745-40: land application and removal to sanitary landfill.

## **OTHER REQUIREMENTS**

### **Compliance Schedule**

***New Chronic Toxicity Limits*** - A 54-month compliance schedule is proposed for the Napoleon WWTP to meet the new monthly average limits for chronic toxicity. Part I,C, Item A and Part II, Item AA.5 provide additional information, including a condition which triggers a Toxicity Reduction Evaluation (TRE) in the event of exceedances of the proposed limit during the interim period.

***Wet Weather Improvement Plan*** - A compliance schedule is proposed for Napoleon WWTP to meet the requirements of the Wet Weather Improvement Plan to reduce CSOs and eliminate SSOs. Details are in Part I.C, Item B of the permit.

### **Sanitary Sewer Overflow Reporting**

Provisions for reporting SSOs are again proposed in this permit. These provisions include: the reporting of the system-wide number of SSO occurrences on monthly operating reports; telephone notification of Ohio EPA and the local health department, and 5-day follow up written reports for certain high risk SSOs; and preparation of an annual report that is submitted to Ohio EPA and made available to the public. Many of these provisions were already required under the “Noncompliance Notification”, “Records Retention”, and “Facility Operation and Quality Control” general conditions in Part III of Ohio NPDES permits.

### **Operator Certification and Operator of Record**

Operator certification requirements have been included in Part II of the permit in accordance with rules effective on August 15, 2018 (OAC 3745-7). These rules require the Napoleon WWTP to have a Class III wastewater treatment plant operator in charge of the sewage treatment plant operations discharging through outfall 001. These rules also require the permittee to designate one or more operator of record to oversee the technical operation treatment works and the sewerage system.

### **Outfall Signage**

Part II of the permit includes requirements for the permittee to place and maintain a sign at each outfall to the Maumee River providing information about the discharge. Signage at outfalls is required pursuant to OAC 3745-33-08(A).

### **Public Water Supply Notification**

An addition to OAC 3745-33-08 requires that permittees discharging wastewater within ten miles of a downstream public water supply intake located on the same waterway must develop and implement notification procedures in conjunction with the downstream public water supply operator in the event of a spill, separate sewer overflow, bypass or upset that reaches waters of the state. Since Campbell Soup Supply Company and the City of Napoleon operate a public water supply in the vicinity of Napoleon WWTP and its collection system discharges, Part II, Item V of the permit requires the permittee to continue to implement previously developed notification procedures after the effective date of the permit.

### **Great Lakes Basin CSO Public Notification**

To comply with the Great Lakes Basin CSO Public Notification rule, the permittee submitted a “CSO/SSP Public Notification Plan on August 6, 2018. The plan was approved by Ohio EPA on August 8, 2018. See Part II, Items C and D for more details.

### **Part III**

Part III of the permit details standard conditions that include monitoring, reporting requirements, compliance responsibilities, and general requirements.

**Storm Water Compliance**

To comply with industrial storm water regulations, the permittee submitted a form for "No Exposure Certification" which was signed on December 21, 2018. The certification number is 2GRN00632\*AG. Compliance with the industrial storm water regulations must be re-affirmed every five years. No later than December 21, 2023, the permittee must submit a new form for "No Exposure Certification" or make other provisions to comply with the industrial storm water regulations.

Figure 1. Location of Napoleon WWTP.

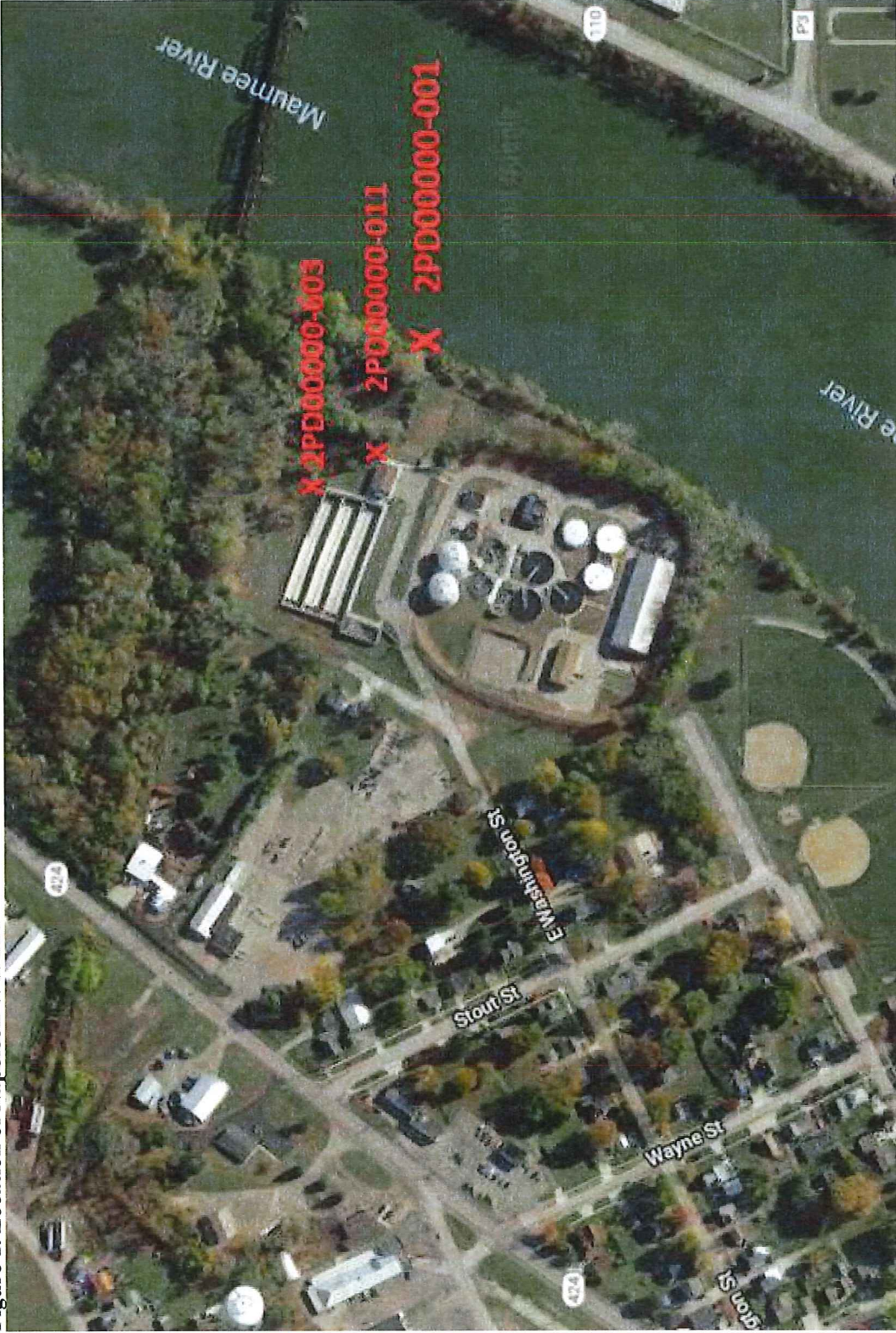
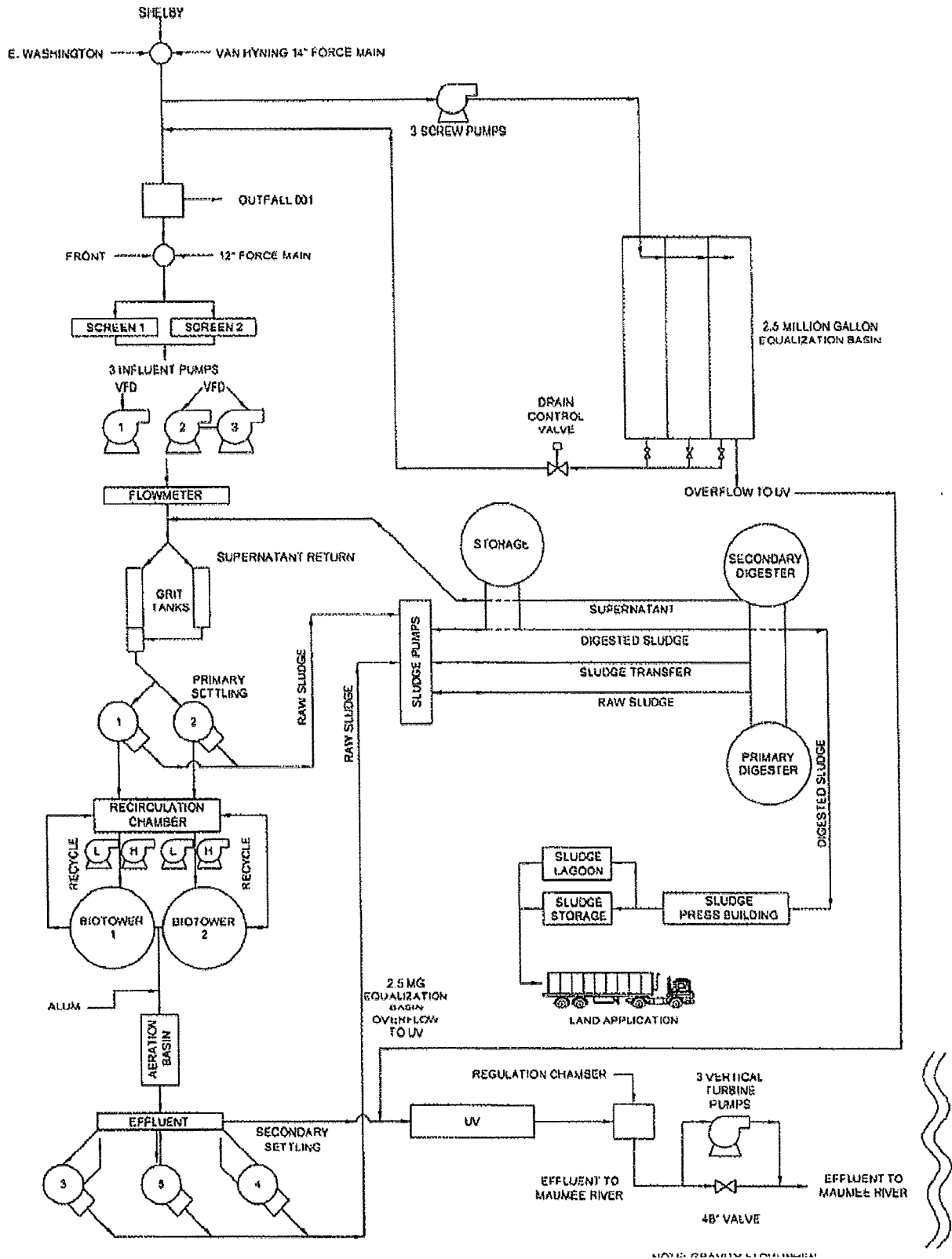

Figure 2. Diagram of Wastewater Treatment System



**Table 1. Sewage Sludge Removal**

Year	Dry Tons Removed
2014	355
2015	374
2016	390
2017	361
2018	370

**Table 2. Average Annual Effluent Flow Rates**

Year	# obs	Flow Rate (MGD)			
		Average	Median	95th Percentile	Maximum
2014 <sup>a</sup>	306	1.70	1.31	4.51	6.27
2015	365	1.76	1.35	4.27	6.49
2016	366	1.68	1.31	3.75	5.36
2017	365	1.81	1.45	4.55	6.03
2018	365	1.78	1.41	4.34	5.79

MGD = million gallons per day.

<sup>a</sup> Period consists of March-December 2014

**Table 3. Sanitary Sewer Overflows Discharges**

Year	Number of SSOs				
	300	302	303	304	305
2014 <sup>a</sup>	5	0	0	0	0
2015	4	0	0	0	0
2016	0	0	0	0	0
2017	0	5	0	0	0
2018	1	1	0	0	0

<sup>a</sup> Period consists of March-December 2014

**Table 4. Combined Sewer Overflow Discharges from Mar. 2014 – Dec. 2018**

Station	Occurrences (#)	Total Volume (MG)	Average Volume (MG)
003	38	1.330	0.038
004	41	0.603	0.015
006	12	0.193	0.016
010	12	0.203	0.017
011	5	4.243	0.606

**Table 5. Bypass Discharges via EQ Basin Overflow**

Year	Occurrences (#)	Total Volume (MG)	Average Volume (MG)
<i>Station 603</i>			
2014 <sup>a</sup>	3	4.13	1.38
2015	3	13.17	4.39
2016	2	0.19	0.09
2017	6	4.85	0.81
2018	3	17.62	5.87

<sup>a</sup> Period consists of March-December 2014

**Table 6. Napoleon WWTP Phosphorus Loading, compared to Annex 4 Target (2008)**

Year	Average Concentration (mg/L)		Annual Average Flow rate (MGD)	Annual Load <sup>b</sup> (kg/yr)	Reduction from 2008 baseline <sup>c</sup> (%)
	Seasonal <sup>a</sup>	Annual			
2008	0.54	0.49	2.04	1316	--
2014	0.68	0.65	1.83	1547	-17.55
2015	0.61	0.67	1.76	1598	-21.43
2016	0.59	0.57	1.68	1268	3.65
2017	0.53	0.51	1.81	1222	7.14
2018	0.40	0.43	1.78	1084	17.63

<sup>a</sup> April-October

<sup>b</sup> Calculated using monthly average concentrations and monthly average flow rates

<sup>c</sup> Negative values indicate increase in loading over 2008 baseline.

**Table 7. Effluent Characterization by Ohio EPA and Napoleon WWTP.**

Parameter	Units	Ohio EPA	Ohio EPA	PS	PS	PS	PS
		3/12/2018	4/24/2018	3/14/2018	6/15/2018	8/3/2018	12/7/2018
Ammonia	mg/L	0.05	0.11	NT	NT	NT	NT
Antimony	µg/L	AA (0.4)	3.51	1	3	3	AA (1)
Arsenic	µg/L	1.49	0.89	AA (0.27)	AA (0.3)	1	AA (0.3)
Cadmium	µg/L	AA (0.2)	AA (0.2)	AA (0.3)	AA (0.1)	AA (0.1)	AA (0.1)
Chromium	µg/L	0.44	AA (0.27)	2	2	2	2
Chloroform	µg/L	0.14	AA (0.44)	AA (0.2)	AA (0.4)	AA (0.4)	AA (0.4)
Copper	µg/L	4.83	4.08	4	2	2	2
Lead	µg/L	1.31	0.35	AA (0.11)	AA (0.1)	AA (0.1)	AA (0.1)
Methyl Chloride	µg/L	0.462	AA (0.49)	AA (0.4)	AA (0.2)	AA (0.2)	AA (0.2)
Molybdenum	µg/L	NT	NT	8	NT	NT	NT
Nickel	µg/L	8.44	8.73	10	7	11	7
Nitrate + Nitrite	mg/L	16.4	8.92	NT	NT	NT	NT
Selenium	µg/L	1.63	1.32	1	AA (0.3)	2	AA (0.3)
Thallium	µg/L	AA (0.17)	0.14	AA (0.3)	AA (0.1)	AA (0.1)	AA (0.1)
Toluene	µg/L	AA (0.28)	AA (0.13)	AA (0.3)	AA (0.3)	AA (0.3)	6.5
Total Filterable Residue	mg/L	876	612	NT	NT	NT	NT
Zinc	µg/L	56.8	37.4	99	24	40	44

AA = not detected (analytical method detection limit)

PS = Pollutant scan by Napoleon WWTP

NT = not tested



**Table 8. Effluent Characterization using electronic Monthly Discharge Reports (eDMR)**

Parameter	Unit	Current Limits			# Obs	Percentiles			Data Range
		30 Day	Daily	Monitor		50th	95th		
Water Temperature	°C	-----Monitor-----			1736	16	23		6 - 25
Dissolved Oxygen (summer)	mg/L	--	5.0 <sup>m</sup>		643	7.8	6.7*		6.1 - 10
Dissolved Oxygen (winter)	mg/L	--	2.0 <sup>m</sup>		560	9.5	8.2*		7.3 - 96
Residue, Total Dissolved	mg/L	-----Monitor-----			19	915	1210		456 - 1220
Total Suspended Solids	kg/day	284	426 <sup>w</sup>		732	61.1	219		3.3 - 684
Total Suspended Solids	mg/L	30	45 <sup>w</sup>		732	11	23		1 - 37
Oil and Grease	mg/L	--	10		116	< 5	2.93		0 - 23
Ammonia (Dec-May)	kg/day	170	255 <sup>w</sup>		345	1.64	6.79		.0475 - 18.5
Ammonia (Dec-May)	mg/L	18	27 <sup>w</sup>		345	.24	.878		.01 - 1.44
Ammonia (June-Sept)	kg/day	15.1	22.7 <sup>w</sup>		256	2.1	7.17		.147 - 19.4
Ammonia (June-Sept)	mg/L	1.6	2.4 <sup>w</sup>		256	.43	1.16		.03 - 2.15
Ammonia (Oct-Nov)	kg/day	31.2	47.3 <sup>w</sup>		131	1.4	8.85		.363 - 19
Ammonia (Oct-Nov)	mg/L	3.3	5.0 <sup>w</sup>		131	.33	1.3		.05 - 2.69
Nitrite + Nitrate	mg/L	-----Monitor-----			58	18.5	27.4		3.5 - 70.7
Phosphorus (2014-15)	kg/day	10	14 <sup>w</sup>		96	3.87	6.99		.882 - 11.6
Phosphorus (2015-18)	kg/day	9.47	14 <sup>w</sup>		186	2.98	6.5		.401 - 11.4
Phosphorus	mg/L	1.0	1.5 <sup>w</sup>		282	.56	.91		.11 - 1.49
Orthophosphate	mg/L	-----Monitor-----			53	.04	.226		.007 - .4
Nickel	µg/L	-----Monitor-----			19	9	12		0 - 12
Zinc	µg/L	-----Monitor-----			19	43	113		24 - 239
Cadmium	µg/L	-----Monitor-----			19	< 3	.2		0 - 2
Lead	µg/L	-----Monitor-----			19	--	--		< 10
Chromium	µg/L	-----Monitor-----			19	< 7	2.02		0 - 2.2
Copper	kg/day	0.256	0.625		39	.0179	.0656		0 - .137
Copper	µg/L	27	66		39	3	5.1		0 - 22.2
Copper	µg/L	-----Monitor-----			7	< 8	90.3		0 - 129
Dissolved Hexavalent Chromium	µg/L	-----Monitor-----			19	--	--		< 10
Fecal Coliform	#/100 mL	1000	2000 <sup>w</sup>		141	1	29		1 - 57

Parameter	Unit	Current Limits		Daily	# Obs	Percentiles			Data Range
		30 Day	30 Day			50th	95th	95th	
<i>E. coli</i>	#/100 mL	126	284 <sup>w</sup>		245	1	9	1 - 104	
Rainfall in Inches	Inches	-----Monitor-----			1736	0	.643	0 - 2.98	
Flow Rate	MGD	-----Monitor-----			1736	1.36	4.28	.736 - 6.49 .00000395 -	
Mercury (2015-18)	kg/day	0.000105	0.016		39	.00000979	.0000323	.0000908 .00000683 -	
Mercury (2014-15)	kg/day	0.000185	0.016		19	.0000107	.0000243	.0000383	
Mercury (2015-18)	ng/L	11.0	1700		39	1.66	4.28	1 - 5.58	
Mercury (2014-15)	ng/L	19.6	1700		19	1.8	3.04	1.3 - 4.3	
Acute Toxicity, <i>Ceriodaphnia dubia</i>	TUa	-----Monitor-----			5	--	--	<.2	
Chronic Toxicity, <i>Ceriodaphnia dubia</i>	TUc	-----Monitor-----			5	<1	5.36	0 - 6.7	
Acute Toxicity, <i>Pimephales promelas</i>	TUa	-----Monitor-----			5	--	--	<.2	
Chronic Toxicity, <i>Pimephales promelas</i>	TUc	-----Monitor-----			5	--	--	<1	
pH, Maximum	S.U.	--	9.0		1203	7.3	7.6	6.6 - 8.1	
pH, Minimum	S.U.	--	6.5 <sup>m</sup>		1203	7.2	6.7	6.5 - 8	
Total Filterable Residue	mg/L	-----Monitor-----			39	827	1040	8 - 1060	
CBOD5 (summer)	kg/day	142	216 <sup>w</sup>		386	12.8	44.2	2.79 - 137	
CBOD5 (summer)	mg/L	15	23 <sup>w</sup>		386	2	6	1 - 12	
CBOD5 (winter)	kg/day	237	379 <sup>w</sup>		346	15.6	58.8	4.15 - 111	
CBOD5 (winter)	mg/L	25	40 <sup>w</sup>		346	3	6	1 - 15	

m = 5th percentile shown  
w = weekly average.

**Table 9. Projected Effluent Quality for Outfall 001**

Parameter	Units	# of Samples	# > MDL	PEQ Average	PEQ Maximum
<i>Parameters unique to Napoleon WWTP</i>					
Antimony	µg/L	6	4	5.38	7.37
Cadmium	µg/L	13	1	2.34	3.20
Mercury	ng/L	59	59	3.05	4.20
Methyl chloride	µg/L	6	1	0.75	1.03
Molybdenum	µg/L	1	1	36.21	49.60
Thallium	µg/L	4	1	0.27	0.36
<i>Parameters in common with Campbell Soup</i>					
Ammonia (summer)	mg/L	256	256	0.75	1.47
Ammonia (winter)	mg/L	165	165	0.63	1.31
Arsenic	µg/L	6	3	2.28	3.13
Chloroform	µg/L	2	1	0.55	0.76
Chromium	µg/L	13	11	2.57	3.52
Dissolved hexavalent chromium	µg/L	20	0	--	--
Copper	µg/L	48	38	5.54	8.30
Lead	µg/L	13	2	1.53	2.10
Nickel	µg/L	22	19	11.62	15.69
Nitrate + nitrite	mg/L	59	59	29.1	40.3
Selenium	µg/L	6	4	3.07	4.20
Toluene	µg/L	6	1	9.96	13.65
Total filterable residue	mg/L	60	60	1070	1331
Zinc	µg/L	22	22	91.69	139.8

MDL = analytical method detection limit

PEQ = projected effluent quality

**Table 10. Summary of Acute and Chronic Toxicity Results**

Date	<i>Ceriodaphnia Dubia</i>		<i>Pimephales promelas</i>	
	TU <sub>a</sub>	TU <sub>c</sub>	TU <sub>a</sub>	TU <sub>c</sub>
Outfall 001				
7/15/2014	AA	AA	AA	AA
7/14/2015	AA	AA	AA	AA
7/1/2016	AA	6.7	AA	AA
7/18/2017	AA	AA	AA	AA
7/17/2018	AA	AA	AA	AA

AA = non-detection; analytical method detection limit of 0.2 TU<sub>a</sub>, 1.0 TU<sub>c</sub>  
 TU<sub>a</sub> = acute toxicity unit  
 TU<sub>c</sub> = chronic toxicity unit

Date	<i>Ceriodaphnia Dubia</i>		<i>Pimephales promelas</i>	
	% Affected		% Affected	
	48-hr	7-day	96-hr	7-day
Outfall 801				
7/15/2014	AA	AA	AA	2.5
7/14/2015	AA	AA	AA	AA
7/1/2016	AA	AA	AA	5
7/18/2017	AA	AA	2.5	7.5
7/17/2018	AA	AA	2.5	20

AA = non-detection

**Table 11. Aquatic Life and Recreational Use Attainment Table**

Location	River Mile	Aquatic Life Use	Status	Causes	Sources
East of Florida, downstream Wade Creek	52.10	mwh	full		
Napoleon, at water works intake	47.10	mwh	full		
Southwest of Liberty Center at railroad bridge, upstream St Rt 109	41.24	mwh	full		
Upstream Grand Rapids dam	32.60	mwh	full		
Grand Rapids, at St Rt 578 (Bridge Street)	31.64	wwh	PARTIAL	Nutrient/Eutrophication Other flow regime alterations	Agriculture Dam/impoundment
Near Otsego at confluence of Sugar Creek	26.70	wwh	full		

Location	River Mile	Recreational Use	Status	Sources
East of Florida, downstream Wade Creek	52.10	primary	full	
Napoleon, at water works intake	47.10	primary	full	
Bridge at St Rt 6	42.50	primary	full	
Upstream Grand Rapids dam	32.60	primary	full	
Grand Rapids, at St Rt 578 (Bridge Street)	31.64	primary	NON	Failing HSTS Waterfowl Accumulation
Near Otsego at confluence of Sugar Creek	26.70	primary	full	

wwh = warmwater habitat  
mwh = modified warmwater habitat  
St Rt = State Route  
Primary = Primary Contact Recreation

**Table 12. Water Quality Criteria in the Study Area**

Parameter	Units	Outside Mixing Zone Criteria					Maximum Aquatic Life	Inside Mixing Zone Maximum
		Wildlife	Average					
			Human Health	Agri- culture	Aquatic Life			
<i>Parameters unique to Napoleon WWTP</i>								
Antimony	µg/L	--	9.7	--	190	900	1800	
Cadmium	µg/L	--	14	50	5.5	14	29	
Mercury	ng/L	1.3	3.1	10000	910	1700	3400	
Methyl chloride	µg/L	--	110 <sup>c</sup>	--	--	--	--	
Molybdenum	µg/L	--	120	--	20000	190000	370000	
Thallium	µg/L	--	--	--	17	79	160	
<i>Parameters in common with Campbell Soup</i>								
Ammonia (summer)	mg/L	--	--	--	0.2	--	--	
Ammonia (winter)	mg/L	--	--	--	2.8	--	--	
Arsenic	µg/L	--	10	100	150	340	680	
Chloroform	µg/L	--	56 <sup>c</sup>	--	140	1300	2600	
Chromium	µg/L	--	140	100	200	4200	8400	
Dissolved hexavalent chromium	µg/L	--	140	--	11	16	31	
Copper	µg/L	--	790	500	22	37	74	
Lead	µg/L	--	--	100	24	450	910	
Nickel	µg/L	--	470	200	120	1100	2200	
Nitrate + nitrite	mg/L	--	10	100	--	--	--	
Selenium	µg/L	--	130	50	5	--	--	
Toluene	µg/L	--	5600	--	62	560	1100	
Total filterable residue	mg/L	--	500	--	1500	--	--	
Zinc	µg/L	--	5000	25000	290	290	570	

<sup>c</sup> = carcinogen

**Table 13. Instream and Discharger Flows**

Parameter	Units	Season	Parameters unique to Napoleon WWTP		Parameters in common with Campbell Soup		Basis
			Value	% of Stream	Value	% of Stream	
<i>Stream Flows</i>							
1Q10	cfs	annual	32	97.65	32	100	USGS 04193500, adj. for area, Campbell Soup intake
7Q10	cfs	annual	68	25	68	25	USGS 04193500, adj. for area, Campbell Soup intake
		summer	--	97.65	--	100	
30Q10	cfs	summer	110	97.65	110	100	USGS 04193500, adj. for area, Campbell Soup intake
		winter	290	97.65	290	100	
90Q10	cfs	annual	177	25	177	25	USGS 04193500, adj. for area, Campbell Soup intake
Harmonic Mean	cfs	annual	653	25	653	25	USGS 04193500, adj. for area, Campbell Soup intake
Discharger flow	cfs	annual	3.87*	--	14.08**	--	*Napoleon WWTP Form 2A (ADF = 2.5 MGD) **Napoleon (2.5 MGD) + Campbell (95 <sup>th</sup> %=6.6 MGD)
<i>Downstream Chemistry</i>							
Hardness, OMZ	mg/l	annual	280	--	280	--	Napoleon WWTP Station 901, n=56, Mar ;14-Dec '18
Hardness, IMZ	mg/l	annual	280	--	280	--	Napoleon WWTP Station 901, n=56, Mar ;14-Dec '18
pH	S.U.	summer	8.7	--	8.7	--	Napoleon WWTP Station 901, n=56, Mar ;14-Dec '18
		winter	8.1	--	8.1	--	Napoleon WWTP Station 901, n=56, Mar ;14-Dec '18
Temperature	C	summer	26.5	--	26.5	--	Napoleon WWTP Station 901, n=56, Mar ;14-Dec '18

WWTP = wastewater treatment plant  
adj. = adjusted  
ADF = average design flow  
n = number of samples

**Table 14. Background Water Quality**

Parameter	Units	Value	n	# < DL	Source	Date	Comments
<i>Parameters unique to Napoleon WWTP</i>							
Antimony	µg/L	--	--	--	--	--	No representative data available.
Cadmium	µg/L	0	7	7	EA3	2012-13	Ohio EPA Station 500200, average
Mercury	ng/L	--	--	--	--	--	No representative data available.
Methyl chloride	µg/L	--	--	--	--	--	No representative data available.
Molybdenum	µg/L	--	--	--	--	--	No representative data available.
Thallium	µg/L	--	--	--	--	--	No representative data available.
<i>Parameters in common with Campbell Soup</i>							
Ammonia (summer)	mg/L	0.05	20	0	eDMR	2014-18	Napoleon WWTP 801, median
Ammonia (winter)	mg/L	0.13	11	0	eDMR	2014-18	Napoleon WWTP 801, median
Arsenic	µg/L	3.34	7	0	EA3	2012-13	Station 500200, average
Chloroform	µg/L	--	--	--	--	--	No representative data available.
Chromium	µg/L	0	7	7	EA3	2012-13	Ohio EPA Station 500200, average
Dissolved hexavalent chromium	µg/L	--	--	--	--	--	No representative data available.
Copper	µg/L	10.41	7	0	EA3	2012-13	Ohio EPA Station 500200, average
Lead	µg/L	1.21	7	6	EA3	2012-13	Ohio EPA Station 500200, average
Nickel	µg/L	6.16	7	0	EA3	2012-13	Ohio EPA Station 500200, average
Nitrate + nitrite	mg/L	0.79	13	5	EA3	2012-13	Ohio EPA Station 500200, median
Selenium	µg/L	0	7	7	EA3	2012-13	Ohio EPA Station 500200, average
Toluene	µg/L	--	--	--	--	--	No representative data available.
Total filterable residue	mg/L	391	7	0	EA3	2012-13	Ohio EPA Station 500200, average
Zinc	µg/L	13.14	7	4	EA3	2012-13	Ohio EPA Station 500200, average

MDL = analytical method detection limit

n = number of samples

Ohio EPA = Ohio Environmental Protection Agency

WWTP = wastewater treatment plant

eDMR = electronic Discharge Monitoring Report



**Table 15. Summary of Effluent Limits to Maintain Applicable Water Quality Criteria**

Parameter	Units	Outside Mixing Zone Criteria					Maximum Aquatic Life	Maximum Aquatic Life	Inside Mixing Zone Maximum
		Average							
		Wildlife	Human Health	Agri-culture	Aquatic Life	Aquatic Life			
<i>Parameters unique to Napoleon WWTP</i>									
Antimony	µg/L	--	419	--	1025	8171	1800		
Cadmium	µg/L	--	605	2160	30	127	29		
Mercury	ng/L	1.3	3.1	10000	910	1700	3400		
Methyl chloride	µg/L	--	4752 <sup>c</sup>	--	--	--	--		
Molybdenum	µg/L	--	5185	--	107898	1724898	370000		
Thallium	µg/L	--	--	--	92	717	160		
<i>Parameters in common with Campbell Soup</i>									
Ammonia (summer)	mg/L	--	--	--	1.37	--	--		
Ammonia (winter)	mg/L	--	--	--	57.79	--	--		
Arsenic	µg/L	--	87	1221	327	1105	680		
Chloroform	µg/L	--	705	--	309	4255	2600		
Chromium	µg/L	--	1763	1259	441	13745	8400		
Dissolved hexavalent chromium	µg/L	--	1763	--	24	52	31		
Copper	µg/L	--	9829	6177	36	97	74		
Lead	µg/L	--	--	1245	52	1470	910		
Nickel	µg/L	--	5848	2447	257	3586	2200		
Nitrate + nitrite	mg/L	--	117	1250	--	--	--		
Selenium	µg/L	--	1637	630	11	--	--		
Toluene	µg/L	--	70529	--	137	1833	1100		
Total filterable residue	mg/L	--	1764	--	2839	--	--		
Zinc	µg/L	--	62820	314709	624	919	570		

<sup>c</sup> = carcinogen

**Table 16. Parameter Assessment**

Group 1: Due to a lack of criteria, the following parameters could not be evaluated at this time.

Group 2: PEQ < 25 percent of WQS or all data below minimum detection limit.  
WLA not required. No limit recommended; monitoring optional.

Arsenic	Chloroform	Chromium
Dissolved hexavalent chromium	Lead	Methyl chloride
Nickel	Thallium	Toluene

Group 3: PEQ<sub>max</sub> < 50 percent of maximum PEL and PEQ<sub>avg</sub> < 50 percent of average PEL.  
No limit recommended; monitoring optional.

Antimony	Cadmium	Copper
Molybdenum	Nitrate + nitrite	Selenium
Zinc		

Group 4: PEQ<sub>max</sub> >= 50 percent, but < 100 percent of the maximum PEL or  
PEQ<sub>avg</sub> >= 50 percent, but < 100 percent of the average PEL. Monitoring is  
appropriate.

Total filterable residue

Group 5: Maximum PEQ >= 100 percent of the maximum PEL or average PEQ >= 100  
percent of the average PEL, or either the average or maximum PEQ is between 75  
and 100 percent of the PEL and certain conditions that increase the risk to the  
environment are present. Limit recommended.

Limits to Protect Numeric Water Quality Criteria

<i>Parameter</i>	<i>Units</i>	<i>Recommended Effluent Limits</i>	
		<i>Average</i>	<i>Maximum</i>
Ammonia (summer)	mg/L	1.4	--
Mercury	ng/L	1.3	1700

PEL = preliminary effluent limit  
PEQ = projected effluent quality  
WLA = wasteload allocation  
WQS = water quality standard

**Table 17. Final Effluent Limits for Outfall 001**

Parameter	Units	Concentration		Loading (kg/day) <sup>a</sup>		Basis <sup>b</sup>
		30 Day Average	Daily Maximum	30 Day Average	Daily Maximum	
Water temperature	°C	-----Monitor-----				M <sup>c</sup>
Dissolved oxygen (summer)	mg/L	--	5.0 <sup>c</sup>	--	--	PD
Dissolved oxygen (winter)	mg/L	--	2.0 <sup>c</sup>	--	--	PD
Total suspended solids	mg/L	30	45 <sup>d</sup>	284	426 <sup>d</sup>	BPT
Oil & grease	mg/L	--	10	--	--	WQS
Ammonia (Dec-May)	mg/L	18	27 <sup>d</sup>	170	255 <sup>d</sup>	PD
Ammonia (Oct-Nov)	mg/L	3.3	5.0 <sup>d</sup>	31.2	47.3 <sup>d</sup>	PD
Ammonia (Jun-Sept)	mg/L	1.4	2.1 <sup>d</sup>	13.3	19.9 <sup>d</sup>	WLA
Nitrate + nitrite	mg/L	-----Monitor-----				BTJ
Total Kjeldahl nitrogen	mg/L	-----Monitor-----				BTJ
Phosphorus	mg/L	1.0	1.5	9.47	14	PTS
Orthophosphate	mg/L	-----Monitor-----				SB1
Nickel	µg/L	-----Monitor-----				BTJ
Zinc	µg/L	-----Monitor-----				BTJ
Lead	µg/L	-----Monitor-----				BTJ
Cadmium	µg/L	-----Monitor-----				BTJ
Chromium	µg/L	-----Monitor-----				BTJ
Copper	µg/L	-----Monitor-----				BTJ
Dissolved hexavalent chromium	µg/L	-----Monitor-----				BTJ
<i>E. coli</i>	#/100 mL	126	284 <sup>d</sup>	--	--	WQS
Rainfall	Inches	-----Monitor-----				BTJ
Flow Rate	MGD	-----Monitor-----				M <sup>c</sup>
Mercury	ng/L	4.2	1700	0.00004	0.016	VAR
Acute toxicity, <i>Ceriodaphnia dubia</i>	TUa	-----Monitor-----				WET
Acute toxicity, <i>Pimephales promelas</i>	TUa	-----Monitor-----				WET
Chronic toxicity, <i>Ceriodaphnia dubia</i>	TUc	2.21	--	--	--	WET/WLA
Chronic toxicity, <i>Pimephales promelas</i>	TUc	--	--	--	--	WET
pH	S.U.	--	6.5-9.0	--	--	WQS
Total filterable residue	mg/L	-----Monitor-----				RP
CBOD5(summer)	mg/L	15	23 <sup>d</sup>	142	216 <sup>d</sup>	PD
CBOD5 (winter)	mg/L	25	40 <sup>d</sup>	237	379 <sup>d</sup>	BPT

<sup>a</sup> Effluent loadings based on average design discharge flow of 2.5 MGD.

<sup>b</sup> Definitions: BPT = Best Practicable Waste Treatment Technology, 40 CFR Part 133, Secondary Treatment Regulation  
BTJ = Best Technical Judgment

CFR = Code of Federal Regulations  
M = Division of Surface Water NPDES Permit Guidance 1: Monitoring frequency requirements for Sanitary Discharges  
NPDES = National Pollutant Discharge Elimination System  
OAC = Ohio Administrative Code  
PD = Plant Design (OAC 3745-33-05(E))  
PTS = Phosphorus Treatment Standards (OAC 3745-33-06 (C))  
RP = Reasonable Potential for requiring water quality-based effluent limits and monitoring requirements in permits (OAC 3745-33-07(A))  
SBI = Implementation of Senate Bill 1 (ORC 6111.03)  
VAR = Mercury variance (OAC 3745-33-07(D)(10)(a))  
WET = Minimum testing requirements for whole effluent toxicity [OAC 3745-33-07(B)(11)]  
WET/WLA = Requiring water quality-based effluent limits and monitoring requirements for whole effluent toxicity in NPDES permits [40 CFR Part 132, Appendix F, Procedure 6 and OAC 3745-33-07(B)]  
WLA = Wasteload Allocation procedures (OAC 3745-2)  
WQS = Ohio Water Quality Standards (OAC 3745-1)

- <sup>c</sup> Monitoring of flow and other indicator parameters is specified to assist in the evaluation of effluent quality and treatment plant performance.
- <sup>d</sup> 7 day average limit.
- <sup>e</sup> Minimum limit

**Addendum 1. Whole Effluent Toxicity Reasonable Potential Calculation**

	Water Flea ( <i>Ceriodaphnia dubia</i> )		Fathead Minnow ( <i>Pimephales promelas</i> )	
	Acute	Chronic	Acute	Chronic
WLA (TU)	1.0	2.21	1.0	2.21
Total # of Tests	5	5	5	5
Maximum Value (TU)	--	6.7	--	--
Coefficient of Variation <sup>1</sup> [Where # tests < 10]	--	0.6	--	--
Multiplying Factors <sup>2</sup>	--	2.3	--	--
PEQ (Maximum Value x Multiplying Factor)	--	15.41	--	--
Reasonable Potential Demonstrated? (Yes if PEQ > WLA)	No <sup>a</sup>	Yes	No <sup>a</sup>	No <sup>a</sup>

<sup>1</sup> 40 CFR Part 132, Appendix F, Paragraph D(3)

<sup>2</sup> 40 CFR Part 132, Appendix F, Table F6-1

<sup>3</sup> All samples were non-detect no reasonable potential observed

## Addendum 2. Acronyms

ABS	Anti-backsliding
BPJ	Best professional judgment
CFR	Code of Federal Regulations
CMOM	Capacity Management, Operation, and Maintenance
CONSWLA	Conservative substance wasteload allocation
CSO	Combined sewer overflow
CWA	Clean Water Act
DMR	Discharge Monitoring Report
DMT	Dissolved metal translator
IMZM	Inside mixing zone maximum
LTCP	Long-term Control Plan
MDL	Analytical method detection limit
MGD	Million gallons per day
NPDES	National Pollutant Discharge Elimination System
OAC	Ohio Administrative Code
Ohio EPA	Ohio Environmental Protection Agency
ORC	Ohio Revised Code
ORSANCO	Ohio River Valley Water Sanitation Commission
PEL	Preliminary effluent limit
PEQ	Projected effluent quality
PMP	Pollution Minimization Program
PPE	Plant performance evaluation
SSO	Sanitary sewer overflow
TMDL	Total Daily Maximum Load
TRE	Toxicity reduction evaluation
TU	Toxicity unit
U.S. EPA	United States Environmental Protection Agency
WET	Whole effluent toxicity
WLA	Wasteload allocation
WPCF	Water Pollution Control Facility
WQBEL	Water-quality-based effluent limit
WQS	Water Quality Standards
WWTP	Wastewater Treatment Plant

Wastewater Treatment Plant  
Improvements  
Project Location

Created: 8/18/20  
Plotted: 9/9/20  
Scale: 1"=400'  
Sheet 01 Of 01

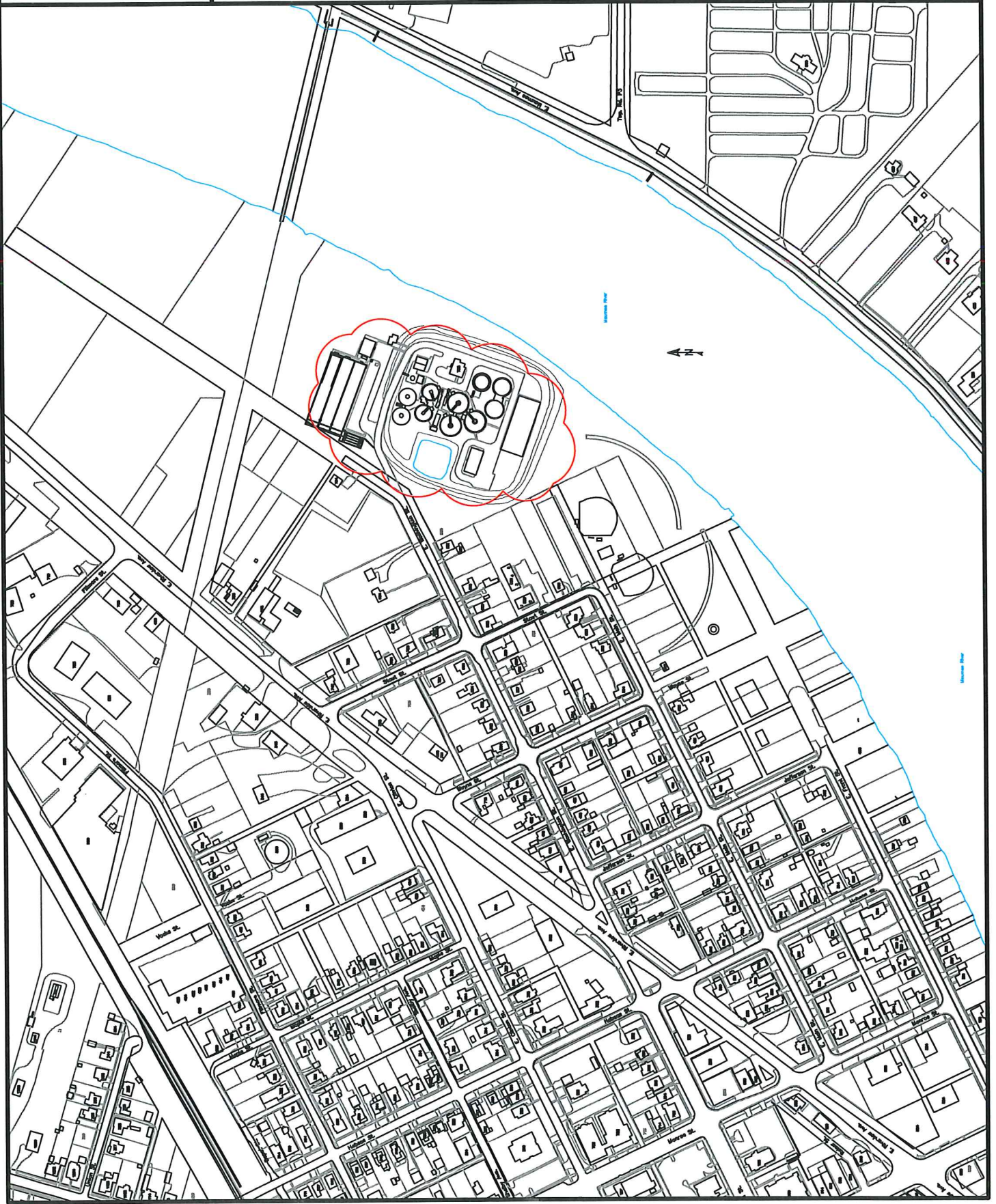

Created: 8/18/20  
Plotted: 9/9/20  
Scale: 1" = 150'  
Sheet 01 of 01

# Wastewater Treatment Plant Improvements Contact: Chad E. Lufts P.E., P.S.

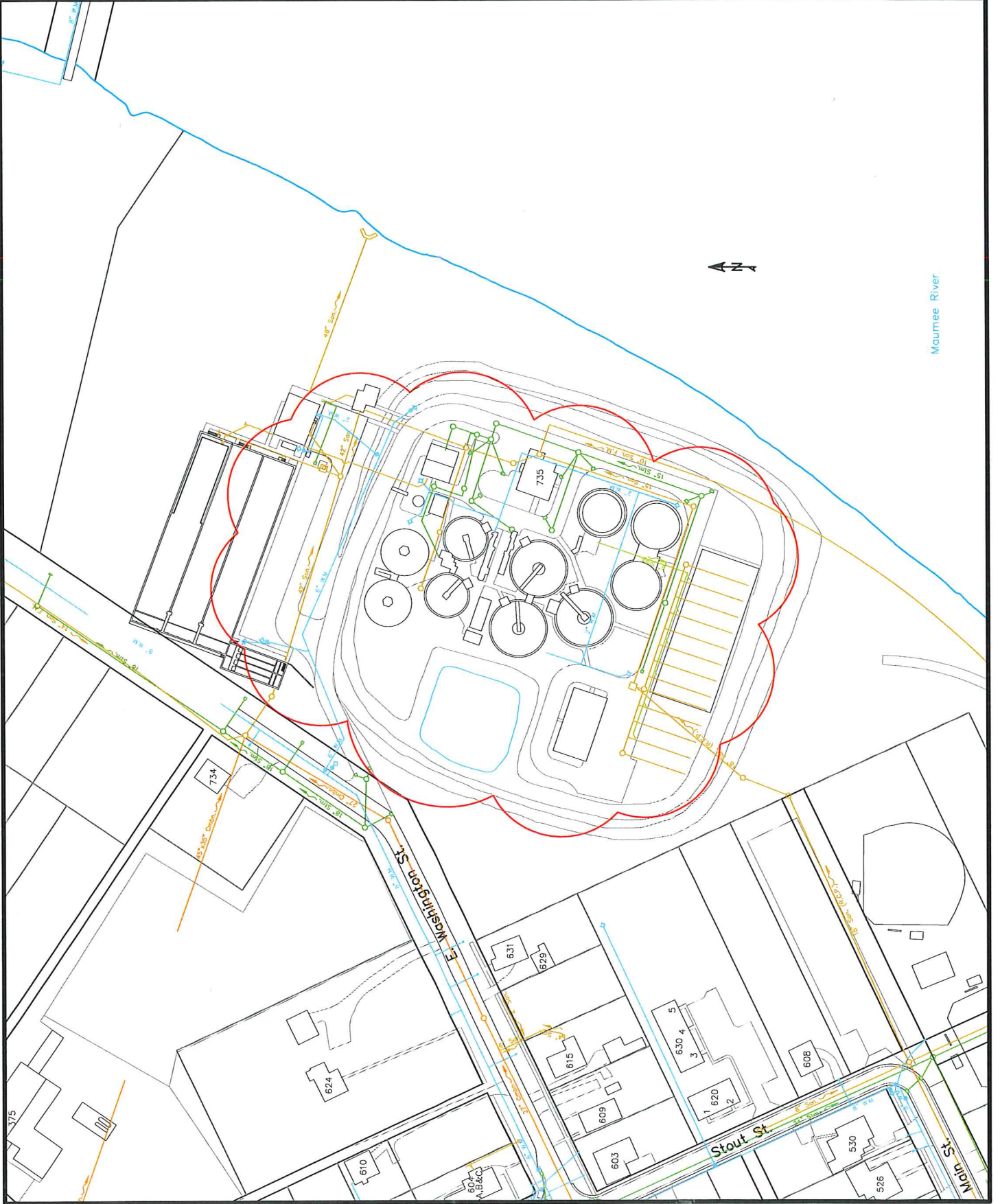



**DISTRICT 5  
CAPITAL IMPROVEMENT PROJECTS  
QUESTIONNAIRE  
ROUND 35**

Name of Applicant: City of Napoleon, Ohio

Project Title: 2021 WWTP Improvements

The following questions are to be answered for each application submitted for State Issue II SCIP, LTIP and Loan Projects. Please provide specific information using the best documentation available to you. Justification of your responses to these questions will be required if your project is selected for funding, so please provide correct and accurate responses. **Communities and Townships under 5,000 in population should also complete the Small Government Criteria.**

1. What percentage of the project is repair A=0%, replacement B=100%, expansion C=0%, and new D=0% (Use dollar amounts of project to figure percentages and make sure the total equals one hundred (100) percent) A+B=100% C+D=0% **ORC Reference(s):164.06(B)(1); 164.14(E)(10)**

Repair/Replacement = Repair or Replacement of public facilities owned by the government (any subdivision of the state).

New/Expansion = Replacement of privately owned wells, septic systems, private water or wastewater systems, etc.

- 2a. Existing Physical Condition of infrastructure **ORC Reference(s):164.06(B)(2);164.14(E)(9);164.14(E)(2); 164.14(E)(8)**

Points	Category	Description	Examples
10	Failing	Infrastructure has reached a point where it requires replacement, reconstruction or reconfiguration to fulfill its purpose	-Intersection Reconfiguration due to accident problem - Structural paving of 3.5" or greater of additional pavement - Pavement Widening to meet ODOT L&D Standards - Complete Pavement Reconstruction - Water or Sewer Line Replacement - Water or Sewer Plant Replacement - Widening graded shoulder width - Complete Bridge or Culvert replacement
8	Poor	The condition is substandard and requires repair or restoration in order to return to the intended level of service and comply with current design standards. Infrastructure contains deficiency and is functioning at a diminished capacity.	-Multiple courses of paving - Structural Culvert Lining - Bridge Deck Replacement - Replacement of a significant part of a water or sewer plant - Single course of paving with 25% base repair- Widening graded shoulder width to less than ODOT L&D Standards

6	Fading	The condition requires reconditioning to continue to function as originally intended.	-Single course of paving -Sewer Lining Projects -Water tower painting -Replacement of pumps, hydrants, valves, filters, etc. in existing water and sewer systems-Widening aggregate berm on existing graded shoulder width
4	Fair	The condition is average, not good or poor. The infrastructure is still functioning as originally intended. Minor deficiencies exist requiring repair to continue to function as originally intended and/or to meet current design standards	
2	Good	The condition is safe and suitable to purpose. Infrastructure is functioning as originally intended, but requires minor repairs and/or upgrades to meet current design standards	
0	Excellent	The condition is new or requires no repair. Or, no supporting documentation has been submitted	

2b. Age of Infrastructure **ORC Reference(s): 164.06(B)(2)**

Life	20	30	50
Project Type	Road	Wastewater and Water Treatment	Bridge/Culvert, Sanitary Sewer, Water Supply, Storm Water, Solid Waste
Points			
0	0-4 Years	0-6 Years	0-10 Years
1	5-8 Years	7-12 Years	11-20 Years
2	9-12 Years	13-18 Years	21-30 Years
3	13-16 Years	19-24 Years	31-40 Years
4	17-20 Years	25-30 Years	41-50 Years
5	20+ Years	30+ Years	50+ Years

3. Health and Safety Rating: **ORC Reference(s): 164.06(B)(4), 164.14(E)(I); 164.14(E)(10)**

If the proposed project is not approved what category would best represent the impact on the general health and/or public safety?

**ROADS**

Extremely Critical: Resurfacing, Restoration, Rehabilitation and Reconstruction (4R) of a Major Access Road.\*

Critical: Resurfacing, Restoration and Rehabilitation (3R) of a Major Access Road.\*

Major:	Resurfacing, Restoration, Rehabilitation and Reconstruction (4R) of a Minor Access Road.*
Moderate:	Resurfacing, Restoration and Rehabilitation (3R) of a Minor Access Road.*
Minimal:	Preventative Maintenance of a Major Access Road.
No Impact:	Preventative Maintenance of a Minor Access Road.

**Projects that have a variety of work will be scored in the LOWEST category of work contained in the Construction Estimate.**

***Road/Street Classifications:***

*Major Access Road:* Roads or streets that have a dual function of providing access to adjacent properties and providing through or connecting service between other roads.

*Minor Access Road:* Roads or streets that primarily provide access to adjacent properties without through continuity, such as cul-de-sacs or loop roads or streets.

*Preventative Maintenance:* Non Structural Pavement work such as chip sealing, cape sealing, micro-surfacing, crack sealing, etc.

\***(3R) Resurfacing, Restoration and Rehabilitation - Improvements to existing roadways, which have as their main purpose, the restoration of the physical features (pavement, curb, guardrail, etc.) without altering the original design elements. (Surface and Intermediate layer Mill and Fills, overlays with less than or equal to 3" of additional pavement, etc.)**

\***(4R) Resurfacing, Restoration, Rehabilitation and Reconstruction - Much like 3R, except that 4R allows for the complete reconstruction of the roadway and alteration of certain design elements (i.e., lane widths, shoulder width, SSD, overlays with greater than 3" of additional pavement, etc.)**

**BRIDGES SUFFICIENCY RATING**

Extremely Critical:	0-25, or a General Appraisal rating of 3 or less.
Critical:	27-50, or a General Appraisal rating of 4.
Major:	51-65 or a General Appraisal rating of 5 or 6.
Moderate:	66-80 or a General Appraisal rating of 7.
Minimal:	81-100 or a General Appraisal rating of more than 7.
No Impact:	Bridge on a new roadway.

**WASTEWATER TREATMENT PLANTS**

**Extremely Critical: X Environmental Protection Agency (EPA) orders in the form of a consent decree, findings and orders or court order. Health Department Construction Ban.**

- Critical: Improvements ordered by the Environmental Protection Agency (EPA) in the form of NPDES Orders.
- Major: Replace deficient appurtenances. Update existing processes due to EPA recommendations.
- Moderate: Increase capacity to meet current needs or update processes to improve effluent quality.
- Minimal: New/Expansion project to meet a specific development proposal.
- No Impact: New/Expansion to meet future or projected needs.

WATER TREATMENT PLANT

- Extremely Critical: EPA orders in the form of a consent decree, findings and orders or court order.
- Critical: Improvements to meet Environmental Protection Agency (EPA) Safe Drinking Water Regulations and/or NPDES Orders.
- Major: Replace deficient appurtenances. Update existing processes due to EPA recommendations.
- Moderate: Increase capacity to meet current needs or update processes to improve water quality.
- Minimal: New/Expansion project to meet a specific development proposal.
- No Impact: New/Expansion to meet future or projected needs.

COMBINED SEWER SEPARATIONS (May be construction of either new storm or sanitary sewer as long as the result is two separate sewer systems.)

- Extremely Critical: EPA orders in the form of a consent decree, findings and orders or court order. Health Department Construction Ban.
- Critical: Separate, due to chronic backup or flooding in basements.
- Major: Separate, due to documented water quality impairment, or due to EPA recommendations.
- Moderate: Separate, due to specific development proposal within or upstream of the combined system area.
- Minimal: Separate, to conform to current design standards.
- No Impact: No positive health effect.

## STORM SEWERS

- Extremely Critical: EPA orders in the form of a consent decree, findings and orders or court order.
- Critical: Chronic flooding (structure damage).
- Major: Inadequate capacity (land damage).
- Moderate: Inadequate capacity with no associated damage.
- Minimal: New/Expansion to meet current needs.
- No Impact: New/Expansion to meet future or project needs.

## CULVERTS

- Extremely Critical: Structurally deficient or functionally obsolete. Deterioration has already caused a safety Critical: hazard to the public.
- Critical: Inadequate capacity with land damage and the existing or high probability of property damage.
- Major: Inadequate capacity (land damage).
- Moderate: Inadequate capacity with no associated damage.
- Minimal: New/Expansion to meet current needs.
- No Impact: New/Expansion to meet future or projected needs.

## SANITARY SEWERS

- Extremely Critical: EPA orders in the form of a consent decree, findings and orders or court order. Health Department Construction Ban.
- Critical: Replace, due to chronic pipe failure, chronic backup or flooding in basements. Improvements ordered by the Environmental Protection Agency (EPA) in the form of NPDES Orders.
- Major: Replace, due to inadequate capacity or infiltration, or due to EPA recommendations.
- Moderate: Rehabilitate to increase capacity to meet current needs or to reduce inflow and infiltration.
- Minimal: New/Expansion project to meet a specific development proposal.
- No Impact: New/Expansion to meet future or projected needs.

## SANITARY LIFT STATIONS AND FORCE MAINS

- Extremely Critical:** Structurally deficient. Deterioration has already caused a safety/health hazard to the public, or EPA orders in the form of a consent decree, findings and orders or court order.
- Critical:** Inadequate capacity with actual or a high probability of property damage. Improvements ordered by the Environmental Protection Agency (EPA) in the form of NPDES Orders.
- Major:** EPA recommendations, or reduces a probable health and/or safety problem.
- Moderate:** Rehabilitate to increase capacity to meet current needs.
- Minimal:** New/Expansion to meet a specific development proposal.
- No Impact:** New/Expansion to meet future or projected needs.

## WATER PUMP STATIONS

- Extremely Critical:** Structurally deficient. Deterioration has already caused a safety hazard to the public, or, EPA orders in the form of a consent decree, findings and orders or court order.
- Critical:** Inadequate capacity with the inability to maintain pressure required for fire flows.
- Major:** Replace due to inadequate capacity or EPA recommendations.
- Moderate:** Rehabilitate to increase capacity to meet current needs.
- Minimal:** New/Expansion to meet a specific development proposal.
- No Impact:** New/Expansion to meet future or projected needs.

## WATERLINES/WATER TOWERS

- Extremely Critical:** Solve low water pressure or excessive incidents of main breaks in project area.
- Critical:** Replace, due to deficiency such as excessive corrosion, etc.
- Major:** Replace undersized water lines as upgrading process.
- Moderate:** Increase capacity to meet current needs.
- Minimal:** New/Expansion project to meet a specific development proposal.
- No Impact:** New/Expansion to meet future or projected needs.

## OTHER

- Extremely Critical:** There is a present health and/or safety threat
- Critical:** The project will provide immediate health and/or safety benefit.

- Major: The project will reduce a probable health and/or safety problem.
- Moderate: The project will delay a health and/or safety problem.
- Minimal: A possible future health and/or safety problem mitigation.
- No Impact: No health and/or safety effect.

*NOTE: Combined projects that can be rated in more than one subset may be rated in the other category at the discretion of the District 5 Executive Committee. In general, the majority of the cost or scope of the project shall determine the category under which the project will be scored*

(Submittals without supporting documentation will receive 0 Points for this question.)

Extremely Critical X, Critical \_\_, Major \_\_, Moderate \_\_, Minimal \_\_, No Impact \_\_. Explain your answer.

(Additional narrative, charts and/or pictures should be attached to questionnaire)

4. Identify the amount of local funds that will be used on the project as a percentage of the total project cost. **ORC Reference 164.06(B)(6); 0RC164.06(B)(7); ORC164.06(B)(3); ORC164.14(E)(4)**

A.) Amount of Local Funds = \$ 14,706,583

B.) Total Project Cost = \$ 14,942,589

RATIO OF LOCAL FUNDS DIVIDED by TOTAL PROJECT COSTS (A/B)= 98 %

Note: Local funds should be considered funds derived from the applicant budget or loans funds to be paid back through local budget, assessments, rates or tax revenues collected by the applicant.

5. Identify the amount of other funding sources to be used on the project, excluding SCIP or LTIP Funds, as a percentage of the total project cost. **ORC Reference(s): 164.06(B)(7); 164.14(E)(4)**

Grants 0 % Gifts 0 %, Contributions 0 %

Other 0 % (explain) \_\_\_\_\_ , Total 0 %

Note: Grant funds and other revenues not contributed or collected through taxes by the applicant should be considered other funds. The Scope of Work for each Funding Source must be the same.

6. Total Amount of SCIP and Loan Funding Requested- An Applicant can request a grant per the categories below for points as indicated on the Priority Rating Sheet. If the Applicant is including a loan request equal to, but not exceeding 50% of the OPWC funding amounts listed below, there will be no point penalty. If loan funds requested are more than 50%, points as listed in the Priority Rating Sheet will apply. **ORC Reference(s): 164.14(E)(10); 164.06(B)(5)**

_____	\$500,001 or More
_____	\$400,001-\$500,000
_____	\$325,001-\$400,000
_____	\$275,001-\$325,000
<u>  X  </u>	\$175,001-\$275,000
_____	\$175,000 or Less

There are times when the District spends all of the grant money and has loan money remaining. When this happens, the district makes a loan offer in the amount of the requested grant to the communities that were not funded. The offers are made in the order of scoring. We need to know if you are not successful in obtaining grant dollars for your project if you would be interested in loan money:

YES \_\_\_\_\_ No   X  

(This will only be considered if you are not funded with grant money and there is remaining loan money.)  
**Please note: if you answer "no" you will not be contacted, only if you answer "yes" will an offer be made in the event that there is loan money remaining.**

7. If the proposed project is funded, will its completion directly result in the creation of permanent full-time equivalent (FTE) jobs (FTE jobs shall be defined as 35 hours/week)? Yes \_\_\_ No   X  . If yes, how many jobs within eighteen months? \_\_\_ Will the completed project retain jobs that would otherwise be permanently lost? Yes \_\_\_ No   X  . If yes, how many jobs \_\_\_\_\_ **will be created/retrained** within 18 months **following the completion of the improvements?**

**ORC Reference(s): 164.14(E)(3);164.14(E)(10)**

(Supporting documentation in the form of letter from affected industrial or commercial enterprises that specify full time equivalent jobs that will be retained or created directly by the installation or improvement of Public infrastructure. Additional items such as; 1) newspaper articles or other media news accounts, 2) public meeting minutes, and/or 3) a letter from the County Economic Development Director or State of Ohio Economic Development Professional that alludes to the requirement for the infrastructure improvement to support the business. Submittals without supporting documentation will receive 0 points for this question.)

8. What is the total number of existing users that will directly benefit from the proposed project if completed?   3,186 Households  . (Use households served, traffic counts, etc. and explain the basis by which you arrived at your number.) **ORC Reference 164.14(E)(7); 164.06(B)(10)**

***Information acquired from City Utility Department.***

9. Economic Distress Criteria **ORC Reference 164.06(B)(8)**

What is the Local Median Household Income as a percentage of the District Median Household Income?  
  83.71   % Please utilize the Economic Distress Scoring Criteria based on ACS 2013-2017 Data provided in Exhibit A.



10. Readiness to Proceed Criteria **ORC Reference 164.06(B)(9); ORC 164.14(E)(S)**

Please categorize the status of planning and design elements for the project.

\_\_\_\_\_ Plans have not begun yet (0 Points)

X  Preliminary Engineering Complete (1 Point) Final Design

\_\_\_\_\_ Complete (2 Points)

11. Base Score Total for Questions 1-10= \_\_\_\_\_

12. County Subcommittee Priority Points= \_\_\_\_\_

(25-20-15 Points for each of the SCIP and LTIP Project Categories)

---

13. **DISCRETIONARY POINTS (BY DISTRICT COMMITTEE ONLY)**

13a. A **District Discretionary Point** may be awarded to projects that demonstrate significant Area-wide, County, or Community Impact. (Include documentation to support the claim of significance) (Maximum of 1 Point at the discretion of the District Executive Committee) \_\_\_\_\_

**ORC Reference 164.14(E)(7)**

13b. A **District Discretionary Point** may be awarded to projects that demonstrate that the entity has maximized local financial resources including assessments. Provide a Fund Status Report and/or the water and sanitary waste utility rate structures are at least 2.5% of area median household income for combined systems and 1.5% of the area median household income for water and sanitary only systems. Please provide rate ordinances for water and sanitary sewer to be considered for discretionary points. (Maximum of 1 Point at the discretion of the District 5 Executive Committee) **ORC Reference 164.06(B)(3)**

14. **Grand Total of Points** \_\_\_\_\_

15. Is subdivision's population less than 5,000 Yes \_\_\_\_\_ No \_\_\_\_\_ If yes, continue. You may want to design your project per Small Government Project Evaluation Criteria, released for the current OPWC Round to assist in evaluating your project for potential Small Government Funding. The Small Government Criteria is available on the OPWC website at

<https://www.pwc.ohio.gov/Portals/O/Data/SmallGovernment%20Round%2035%20Methodology.pdf?ver=2019-08-07-071749-143>

---

16. **OHIO PUBLIC WORKS COMMISSION SMALL GOVERNMENT PROGRAM GUIDELINES**

All projects that are sponsored by a subdivision with a population of 5,000 or less, and not earning

enough points for District Funding from SCIP or LTIP Funds, are then rated using the Small Government Program Rating Criteria for the corresponding funding round. In order to be rated the entity must submit the Small Government Supplement and their required budgets with their application. **Only infrastructure that is village- or township- owned is eligible for assistance.** The following policies have been adopted by the Small Government Commission:

- District Integrating Committees may submit up to seven (7) applications for consideration by the Commission. All 7 must be ranked, however, only the top five (5) will be scored. The remaining two (2) will be held as contingency projects should an application be withdrawn.
- Grants are limited to \$500,000. Any assistance above that amount must be in the form of a loan.
- Grants for new or expanded infrastructure cannot exceed 50% of the project estimate.
- The Commission may deny funding for water and sewer systems that are deemed to be more cost-effective if regionalized.
- If a water or sewer project is determined to be affordable, the project will be offered a loan rather than a grant. Pay special attention to the **Water & Wastewater Affordability Supplemental and the Small Government Water & Wastewater Affordability Calculation Worksheet. Both are available on the Small Government Program Tab at <https://www.pwc.ohio.gov/Programs/Infrastructure-Programs/Small-Government>**
- Should there be more projects that meet the "annual score" than there is funding, the tie breaker is those projects which scored highest under Health & Safety, with the second tie breaker being Condition. If multiple projects have equivalent Health & Safety and Condition scores they are arranged according to the amount of assistance from low to high. Once the funded projects are announced, "contingency projects" may be funded from project under-runs by continuing down the approved project list.
- Supplemental assistance is not provided to projects previously funded by the Commission.
- Applicants have 30 days from receipt of application by OPWC without exception to provide additional documentation to make the application more competitive under the Small Government criteria. Applications will be scored after the 30-day period has expired. The applicants for each District's two (2) contingency projects will have the same 30-day period to submit supplemental information but these applications will not be scored unless necessary to do so. **It is each applicant's responsibility for determining the need for supplemental material. The applicant will not be asked for or notified of missing information unless the Commission has changed the project type and it affects the documentation required. Important information may include, but is not limited to: age of infrastructure, traffic counts or utility users, median income information, user rates ordinances, and the Auditor's Certificate of Estimated Revenues or documentation from the Auditor of State that subdivision is in a state of fiscal emergency.**

If you desire to have your Round 35 project considered for Small Government Funding please download the Small Government Evaluation Criteria applicable to Round 35 by accessing the OPWC Website at

<https://www.pwc.ohio.gov/Portals/0/Data/SmallGovernment%20Round%2035%20Methodology.pdf?>

Please complete the Small Government Evaluation Criteria and attach all required supporting documentation and attach it to the District 5 Questionnaire for Round 35.

Date: September 9, 2020

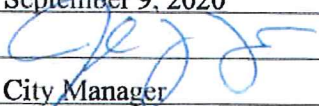
Signature: 

Title: City Manager

Address: 255 W. Riverview Avenue, Napoleon, Ohio 43545

Phone: 419.592.4010

FAX: 419.599.8393

Email: [jmazur@napoleonohio.com](mailto:jmazur@napoleonohio.com)